

SECTION 3
Wire Rope Assembly and Fittings

ASSEMBLIES, CABLE		FITTINGS, WIRE ROPE		STOPS	
Fittings.....	3-13-18	Bail Socket	3-4	Compression	3-13
How to Measure.....	3-13	Button	3-5	SWAGED FITTING, CABLE	
Illustration.....	3-13	Clevis Socket Assembly	3-11	Ball	3-16-17
ASSEMBLIES, WIRE ROPE		Cold Tuff®.....	3-5	Deck	3-17-18
Positive Grip.....	3-8-13	Coupling Assembly.....	3-10	Eye	3-15-16
Spelter Sockets	3-1	Drum Socket Assembly.....	3-10	Fork	3-15-16
Swage Sockets	3-3	Eye	3-4-5	Sleeves	3-12-13
BAIL		Eye Socket	3-10	Stops	3-13
Sockets, Wire Rope	3-4	Ferrules	3-7-8	Stud	3-14
BOOM PENDANT		Jaw End	3-4	Terminals	3-14-18
Inspection.....	3-1	Positive Grip.....	3-8-12	Toggle.....	3-17-18
Thimbles.....	3-1	Plugs	3-9	Turnbuckles.....	3-17-18
BUTTON		Shank Hooks.....	3-4	SWAGED FITTING, WIRE ROPE	
Swage Fittings.....	3-5	Spelter Sockets	3-2	Bail Socket	3-4
CABLE		Stud	3-5	Button	3-5
Assemblies	3-13	Stud Socket Assembly.....	3-11	Cold Tuff®.....	3-5
Compression Sleeves	3-12-13	Super Terminator Wedge Socket	3-7	Eye	3-4-5
End Fitting.....	3-14-18	Swage Sockets	3-3-4	Jaw End	3-4
Terminals.....	3-14-18	Terminator Wedge Socket.....	3-6	Shank Hooks.....	3-4
COLD TUFF® SWAGE FITTING	3-5	Turnbuckle.....	3-12	Sockets.....	3-3-4
COMPRESSION		Wedge Socket.....	3-6-7	Stud	3-5
Sleeves, Wire Rope	3-12-13	HOOK		TERMINALS	
Stops, Wire Rope	3-13	Swageable Shank	3-4	Cable.....	3-14-18
FERRULES, WIRE ROPE		PENDANT BOOM		Wire Rope	3-2-13
Installation Procedures.....	3-7	Inspection.....	3-1	THIMBLES	
Pointed Zinc	3-7	Thimbles.....	3-1	Boom Pendant	3-1
Wedge.....	3-8	PINS		TURNBUCKLES	
Zinc	3-7	Clevis	3-15	Positive Grip Fitting.....	3-12
FITTINGS, CABLE ENDS		Cotter	3-15	Swaged Fitting	3-17-18
Ball	3-16-17	POSITIVE GRIP		WEDGE	
Deck	3-17-18	Wire Rope Assemblies/Fittings	3-8-12	Sockets.....	3-6-7
Eye	3-15-16	RESIN		Socket, Assemblies	3-6
Fork	3-15-16	Spelter Socket	3-2	Socket, Safety	3-6
Sleeves	3-12-13	SLEEVES		Super Terminator.....	3-7
Stops	3-13	Compression	3-12-13	Terminator	3-6
Stud	3-14	SOCKETS, WIRE ROPE		WIRE ROPE	
Terminals.....	3-14-18	Bail	3-4	Assemblies	3-1, 3-3, 3-8-12
Toggle.....	3-17-18	Spelter	3-2	Ferrules	3-7-8
Turnbuckles.....	3-17-18	Swage	3-3-4	Fitting	3-1-13
		Wedge	3-6-7	Positive Grip Assemblies.....	3-8-12
		SPELTER		Sleeves	3-12-13
		Socket	3-2	Sockets	3-1-4, 3-6-7, 3-10-11
		Socket Assemblies.....	3-1	Studs	3-5
		Socket Resin	3-2	Swage Fittings	3-3-5, 3-12-13
				Terminals.....	3-2-12

Wire Rope Assembly & Fittings

Boom Penants/Spelter Sockets

General Guide to Boom Pendant Inspection

1. Measure the diameter of the rope at several points along the pendant especially near the end fittings.
 - Measurements below the ropes nominal diameter may mean that the core is deteriorating, even if the outside wires and strands appear to be in good condition.
2. Inspect the outside wires and strands for damaging rust or abrasive wear caused by loss of lubrication or by the rope's contact with the boom or other structures on the crane.
3. Inspect the rope for broken wires—especially near the end fittings.
 - Even one broken wire near an end fitting may be a sign that the rope is deteriorating and may be near failure.
 - Any "valley breaks," that is, wires that have broken in the valley between two strands may also be a sign that there is serious vibration fatigue in the core.
4. Inspect the fitting attachments.



Watch for broken wires in this area.



The socket must be replaced.

- Flemish Eye Swaged:** Look for any sign that the sleeve may be cracked, crushed or peeling back.
- Swaged Sockets:** Look for any signs of a cracked or bent shank. Look for any sign that the rope may be pulling out of the socket.
5. Inspect the End Fittings: Inspect the fittings for any signs of cracking or distortion. Pay particular attention to the area around the pin holes and along the ears of open sockets.
 - Inspect the pin holes for any signs of elongation or excessive wear.
 - Inspect the socket pins for any signs of bending or excessive wear.

Note: If any of the above conditions exist, the pendant should be removed from service and inspected or tested further. This is intended to be a general guide only. Contact the manufacturer of the equipment. The pendants, and/or the end fittings to get specific retirement criteria.

3 Wire Rope Assembly and Fittings

Poured Zinc or Thermo-Set Resin Sockets: Look at the base of the sockets for any signs that the wires may be pulling out of the zinc or thermo-set resin. Look at the top of the cone for any sign that the zinc or thermo-set resin is cracked or is chipping or flaking off.

Boom Pendant Thimbles

The BOOM PENDANT is fabricated with a flemish eye splice and swaged steel sleeves which fit around a pendant fitting that is either open or closed. Available in sizes from 9/16" to 2-1/8".

Pendants are not to be used for any other purpose other than BOOM PENDANT application. PENDANT THIMBLES are interchangeable with standard sockets. Weight on open pendant includes pin (D) and cotter.

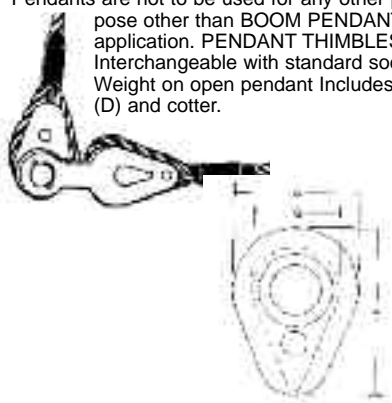

Wire Rope Dia. Inches	Open Dimensions (in)												Est. Wt. Lbs.
	A	B	C	D	E	F	G	H	J	L	P	R	
9/16 - 5/8	8-3/64	2-3/8	1-1/4	1-3/16	15/32	11/16	2-1/8	3-1/8	2-17/32	4-1/4	2-9/32	9/16	5.3
3/4	9-9/32	2-13/16	1-1/2	1-3/8	17/32	13/16	2-1/2	3-5/8	3-1/32	4-3/4	2-3/4	21/32	7.5
7/8	10-5/16	3-1/4	1-3/4	1-5/8	5/8	15/16	2-3/4	4-1/8	3-1/4	5-1/4	3-1/4	3/4	12.5
1	11-11/16	3-3/4	2	2	3/4	1-1/8	3	4-9/16	3-11/16	5-7/8	3-7/8	7/8	19.
1-1/8	12-25/32	4-1/4	2-1/4	2-1/4	7/8	1-1/4	3-1/4	5-1/16	3-27/32	6-17/32	4-7/16	1	26.
1-1/4 - 1-3/8	15-1/32	4-3/4	2-1/2	2-1/2	15/16	1-1/2	4	6-1/8	4-5/16	8	4-15/16	1-1/8	39.
1-1/2	17-1/8	5-3/8	3	2-3/4	1-1/16	1-5/8	4-1/2	6-3/4	4-13/16	9-1/8	5-5/8	1-3/16	56.
1-5/8	20-1/2	5-5/8	3	3	1-3/16	1-3/4	5-1/2	8	6-7/16	10-5/8	6-1/8	1-5/16	82.
1-3/4 - 1-7/8	24-1/16	6-5/8	3-1/2	3-1/2	1-5/16	2	7	9-3/4	7-7/16	12-3/4	6-7/8	1-9/16	125.
2 - 2-1/8	27	7-5/8	4	3-3/4	1-11/16	2-1/4	8	10-3/4	9-3/4	13-1/4	7-1/8	1-13/16	166.

Wire Rope Dia. Inches	Closed Dimensions (in)							Est. Wt. (Lbs.)
	A	B	C	D	E	F	G	
9/16 - 5/8	4-3/32	3-1/8	1-1/4	1-1/16	1-1/16	11/16	2-1/8	1.7
3/4	4-27/32	3-5/8	1-7/16	1-5/16	1-3/16	13/16	2-1/2	2.6
7/8	5-5/16	4-1/8	1-11/16	1-1/2	1-3/8	15/16	2-3/4	3.5
1	5-31/32	4-9/16	2-1/16	1-3/4	1-5/8	1-1/8	3	4.6
1-1/8	6-3/8	5-1/16	2-5/16	2	1-3/4	1-1/4	3-1/4	5.6
1-1/4 - 1-3/8	7-3/8	6-1/8	2-9/16	2-1/4	2-1/8	1-1/2	4	9.6
1-1/2	8-3/16	6-3/4	2-13/16	2-1/2	2-3/8	1-5/8	4-1/2	14.
1-5/8	10-7/16	8	3-1/16	2-5/8	2-1/2	1-3/4	5-1/2	29.
1-3/4 - 1-7/8	12-5/16	9-3/4	3-9/16	3-1/8	3	2	7	41.
2 - 2-1/8	13	10-1/2	3-13/16	3-7/16	3-1/4	2-1/4	7-1/2	57.
2-1/4 - 2-3/8	17-5/16	11-3/4	4-3/8	3-7/8	3-5/8	2-1/2	8-1/2	76.

Spelter Socket Assemblies

Wire Rope assemblies with fittings permanently attached at ends are custom fabricated for use as boom pendants, guylines, raising lines, backstays, lifting bridle, etc. These are offered in both poured, or spelter, sockets and mechanically swaged sockets. A Design Factor of five is applied in establishing Rated Capacities shown.

Molten zinc is standard as the bonding medium surrounding wires inside the socket, but epoxy compound may be specified on special order. Both mediums have same capacity ratings. Steel forgings are used for rope sizes 1/2" through 1-1/2" and cast steel fittings for larger sizes. Larger than 4" available on special order. Assembly length is measured from centerline of pin for open sockets and bearing point for closed sockets.

Rope Dia.	Open Socket Dimensions (in)						Closed Socket Dimensions (in)							
	C	D	F	J	L	M	B	C	D	E	F	J	K	L
1/2	1.00	1.00	.56	2.50	2.00	1.94	.69	2.00	1.13	.44	.56	2.50	.88	2.31
9/16 - 5/8	1.25	1.19	.69	3.00	2.50	2.25	.81	2.63	1.38	.63	.69	3.00	1.00	2.56
3/4	1.50	1.38	.81	3.50	3.00	2.63	1.06	3.00	1.63	.69	.81	3.50	1.25	3.06
7/8	1.75	1.63	.97	4.00	3.50	3.13	1.31	3.63	1.88	.88	.97	4.00	1.50	3.56
1	2.00	2.00	1.13	4.50	4.00	3.75	1.44	4.13	2.25	.94	1.13	4.50	1.75	4.06
1-1/8	2.25	2.25	1.25	5.00	4.50	4.13	1.56	4.50	2.50	1.00	1.25	5.00	2.00	4.56
1-1/4 - 1-3/8	2.50	2.50	1.50	5.50	5.00	4.75	1.69	5.00	2.75	1.13	1.50	5.50	2.25	5.13
1-1/2	3.00	2.75	1.63	6.00	6.00	5.38	2.00	5.38	3.13	1.13	1.63	6.00	2.50	6.13
1-5/8	3.00	3.00	1.75	6.50	6.50	5.75	2.13	5.75	3.25	1.25	1.75	6.50	2.75	6.75
1-3/4 - 1-7/8	3.50	3.50	2.00	7.50	7.00	6.50	2.19	6.75	3.53	1.50	2.00	7.50	3.00	7.81
2 - 2-1/8	4.00	3.75	2.25	8.50	9.00	7.00	2.44	7.63	3.78	1.63	2.25	8.50	3.25	8.81
2-1/4 - 2-3/8	4.50	4.25	2.56	9.00	10.00	7.75	2.88	8.50	4.28	1.75	2.50	9.00	3.63	9.75
2-1/2 - 2-5/8	5.00	4.75	2.88	9.75	10.75	8.50	3.12	9.50	5.5	2.00	2.88	9.75	4.00	10.62
2-3/4 - 2-7/8	5.25	5.00	3.12	11.00	11.00	9.00	3.00	10.75	6.25	2.25	3.12	11.00	4.88	11.25
3 - 3-1/8	5.75	5.25	3.38	12.00	11.25	9.50	3.25	11.50	6.75	2.38	3.38	12.00	5.25	11.75
3-1/4 - 3-5/8	6.25	5.50	3.62	13.00	11.75	10.00	4.00	12.25	7.25	2.50	3.62	13.00	5.75	12.25
3-1/2 - 3-5/8	6.75	6.00	3.88	14.00	12.50	10.75	4.00	13.00	7.75	2.62	3.88	14.00	6.25	13.00
3-3/4 - 4	7.50	7.00	4.25	15.00	13.50	12.50	4.25	14.25	8.50	2.88	4.25	15.00	7.00	14.00

Rope Dia.	Capacity (Tons*)	
	6x19 & 6x37 IWRC	
	IPS	XIP
1/2	2.3	2.66
9/16	2.9	3.36
5/8	3.58	4.12
3/4	5.12	5.88
7/8	6.92	7.96
1	8.98	10.34
1-1/8	11.3	13.
1-1/4	13.88	15.98
1-3/8	16.7	19.2
1-1/2	19.78	22.8
1-5/8	23.	26.4
1-3/4	26.6	30.6
1-7/8	30.4	34.8
2	34.4	39.6
2-1/8	38.4	44.2
2-1/4	43.	49.4
2-3/8	47.8	54.8
2-1/2	52.4	60.4
2-5/8	57.6	66.2
2-3/4	62.8	72.2
2-7/8	68.2	78.4
3	74.	85.
3-1/8	79.8	91.6
3-1/4	85.8	98.4
3-3/8	91.8	105.8
3-1/2	98.2	112.8
3-5/8		
3-3/4	109.8	126.4
4	124.	142.6

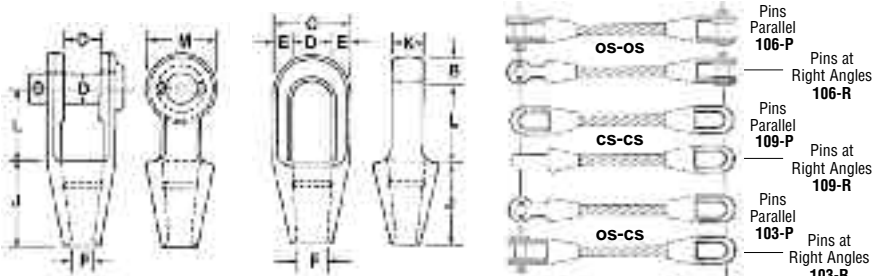

Wire Rope Assembly & Fittings

Spelter Sockets

Grooved Open Spelter Socket

G-416 Crosby

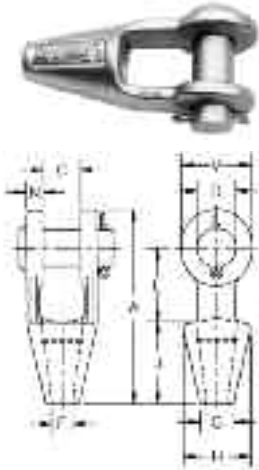

Note: Above drawing illustrates one groove used on sockets 1/4" thru 3/4". Sizes 7/8" thru 1-1/2" use 2 grooves. Sizes 1-5/8" & larger use 3 grooves.

- Forged Steel Sockets thru 1-1/2", cast alloy steel 1-5/8" thru 4".
- Spelter socket terminations have an efficiency rating of 100%, based on the catalog strength of wire rope. Ratings are based on recommended use with 6 x 7,

6 x 19, or 6 x 37, IPS or XIP (EIP), XXIP (EEIP), RRL, FC, or IWRC wire rope.

- Notice: All cast steel sockets 1-5/8" & larger are magnetic particle inspected & ultrasonic inspected. Proof testing available on special order.

Rope Dia. (in.)	Structural Strand Data (in.)	Stock No.		Wt. Each (lbs.)	Dimensions (in)										
		G-416 Galv.	S-416 S.C.		A	C	D	F	G	H	J	L	M	N	
1/4	-	1039619	1039628	1.10	4.56	.91	.69	.38	.69	1.56	2.25	1.56	1.31	.36	
5/16 - 3/8	-	1039637	1039646	1.30	4.84	.81	.50	.81	1.69	2.25	1.75	1.50	.44		
7/16 - 1/2	-	1039655	1039664	2.25	5.56	1.00	1.00	.56	.94	1.88	2.50	2.00	1.88	.50	
9/16 - 5/8	1/2	1039673	1039682	3.60	6.75	1.25	1.19	.69	1.13	2.25	3.00	2.50	2.25	.56	
3/4	9/16 - 5/8	1039691	1039708	5.83	7.94	1.50	1.38	.81	1.25	2.62	3.50	3.00	2.62	.62	
7/8	11/16 - 3/4	1039717	1039726	9.65	9.25	1.75	1.63	.94	1.50	3.25	4.00	3.50	3.13	.80	
1	13/16 - 7/8	1039735	1039744	15.50	10.56	2.00	2.00	1.13	1.75	3.75	4.50	4.00	3.75	.88	
1-1/8	15/16 - 1	1039753	1039762	21.50	11.81	2.25	2.25	1.25	2.00	4.12	5.00	4.62	4.12	1.00	
1-1/4 - 1-3/8	1-1/16 - 1-1/8	1039771	1039780	31.00	13.19	2.50	2.50	1.50	2.25	4.75	5.50	5.00	4.75	1.13	
1-1/2	1-13/16 - 1-1/4	1039799	1039806	47.25	15.12	3.00	2.75	1.63	2.75	5.25	6.00	6.00	5.38	1.19	
1-5/8	1-15/16 - 1-3/8	1039815	1039824	55.00	16.25	3.00	3.00	1.75	3.00	5.50	6.50	6.50	5.75	1.31	
1-3/4 - 1-7/8	1-7/16 - 1-5/8	1039833	1039842	82.00	18.25	3.50	3.50	2.00	3.13	6.38	7.50	7.00	6.50	1.56	
2 - 2-1/8	1-11/16 - 1-3/4	1039851	1039860	129.00	21.50	4.00	3.75	2.25	3.75	7.38	8.50	9.00	7.00	1.81	
2-1/4 - 2-3/8	1-13/16 - 1-7/8	1039879	1039888	167.00	23.50	4.50	4.25	2.50	4.00	8.25	9.00	10.00	7.75	2.13	
2-1/2 - 2-5/8	1-15/16 - 2-1/8	1041633	1041642	252.00	25.50	5.00	4.75	2.88	4.50	9.25	9.75	10.75	8.50	2.38	
2-3/4 - 2-7/8	2-3/16 - 2-7/16	1041651	1041660	315.00	27.25	5.25	5.00	3.12	4.88	10.50	11.00	11.00	9.00	2.88	
3 - 3-1/8	2-1/2 - 2-5/8	1041679	1041688	380.00	29.00	5.75	5.25	3.38	5.25	11.12	12.00	11.25	9.50	3.00	
3-1/4 - 3-3/8	2-3/4 - 2-7/8	1041697	1041704	434.00	30.88	6.25	5.50	3.62	5.75	11.88	13.00	11.75	10.00	3.12	
3-1/2 - 3-5/8	3-3-1/8	1041713	1041722	563.00	33.25	6.75	6.00	3.88	6.50	12.38	14.00	12.50	10.75	3.25	
3-3/4 - 4	-	1041731	1041740	783.00	36.25	7.50	7.00	4.25	7.25	13.62	15.00	13.50	12.50	3.50	

Grooved Closed Spelter Socket

G-417 Crosby

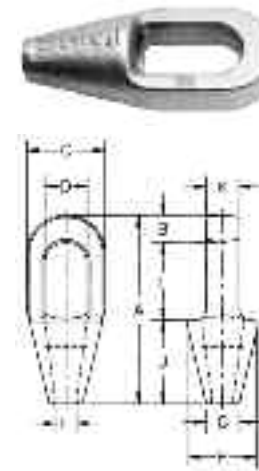

Note: Above drawing illustrates one groove used on sockets 1/4" thru 3/4". Sizes 7/8" thru 1-1/2" use 2" grooves. Sizes 1-5/8" & larger use 3 grooves.

- Forged Steel Sockets thru 1-1/2", cast alloy steel 1-5/8" thru 4".
- Spelter socket terminations have an efficiency rating of 100%, based on the catalog strength of wire rope. Ratings are based on recommended use with 6 x 7,

6 x 19, or 6 x 37, IPS or XIP (EIP), XXIP (EEIP), RRL, FC, or IWRC wire rope.

- Notice: All cast steel sockets 1-5/8" & larger are magnetic particle inspected & ultrasonic inspected. Proof testing available on special order.

Rope Dia. (in.)	Structural Strand Data (in.)	Stock No.		Wt. Each (lbs.)	Dimensions (in)										
		G-417 Galv.	S-417 S.C.		A	B	C	D	F	G	H	J	K	L	
1/4	-	1039897	1039904	.50	4.50	.50	1.50	.88	.38	.69	1.56	2.25	.50	1.75	
5/16 - 3/8	-	1039913	1039922	.75	4.88	.62	1.69	.97	.50	.81	1.69	2.25	.69	2.00	
7/16 - 1/2	-	1039931	1039940	1.50	5.44	.69	2.00	1.16	.56	.94	1.88	2.50	.88	2.25	
9/16 - 5/8	1/2	1039959	1039968	2.50	6.31	.81	2.63	1.41	.69	1.12	2.38	3.00	1.00	2.50	
3/4	9/16 - 5/8	1039977	1039986	4.25	7.56	1.06	3.00	1.66	.81	1.25	2.75	3.56	1.25	3.00	
7/8	11/16 - 3/4	1039995	1040000	7.25	8.75	1.25	3.63	1.88	.94	1.50	3.25	4.00	1.50	3.50	
1	13/16 - 7/8	1040019	1040028	10.50	9.88	1.38	4.13	2.30	1.13	1.75	3.75	4.44	1.75	4.00	
1-1/8	15/16 - 1	1040037	1040046	14.25	11.00	1.50	4.50	2.56	1.25	2.00	4.13	5.00	2.00	4.50	
1-1/4 - 1-3/8	1-1/16 - 1-1/8	1040055	1040064	19.75	12.12	1.63	5.30	2.81	1.50	2.25	4.75	5.50	2.25	5.00	
1-1/2	1-3/16 - 1-1/4	1040073	1040082	29.20	13.94	1.94	5.33	3.19	1.63	2.75	5.25	6.00	2.50	6.00	
1-5/8	1-5/16 - 1-3/8	1040091	1040108	36.00	15.13	2.13	5.75	3.25	1.75	3.00	5.50	6.50	2.75	6.50	
1-3/4 - 1-7/8	1-7/16 - 1-5/8	1040117	1040126	57.25	17.25	2.19	6.75	3.75	2.00	3.13	6.38	7.50	3.00	7.56	
2 - 2-1/8	1-11/16 - 1-3/4	1040135	1040144	79.00	19.50	2.44	7.63	4.38	2.25	3.75	7.38	8.50	3.25	8.56	
2-1/4 - 2-3/8	1-13/16 - 1-7/8	1040153	1040162	105.00	21.13	2.63	8.50	5.00	2.50	4.00	8.25	9.00	3.63	9.50	
2-1/2 - 2-5/8	1-15/16 - 2-1/8	1041759	1041768	140.00	23.50	3.12	9.50	5.50	2.88	4.50	9.25	9.75	4.00	10.62	
2-3/4 - 2-7/8	2-3/16 - 2-7/16	1041777	1041786	220.00	25.38	3.12	10.75	6.25	3.12	4.88	10.19	11.00	4.88	11.25	
3 - 3-1/8	2-1/2 - 2-5/8	1041795	1041802	276.00	27.00	3.25	11.50	6.75	3.38	5.25	11.50	12.00	5.25	11.75	
3-1/4 - 3-3/8	2-3/4 - 2-7/8	1041811	1041820	313.00	29.25	4.00	12.25	7.25	3.62	5.75	12.25	13.00	5.75	12.25	
3-1/2 - 3-5/8	3 - 3-1/8	1041839	1041848	400.00	31.00	4.00	13.00	7.75	3.88	6.50	13.00	14.00	6.25	13.00	
3-3/4 - 4	-	1041857	1041866	542.00	33.25	4.25	14.25	8.50	4.25	7.25	14.25	15.00	7.00	14.00	

Resin for Spelter Sockets - Wirelock® W416-7

Socket Compound



- 100% termination efficiency.
- Temperature operating range is -65° F to +240° F.
- Ideal for on site applications.
- No hazardous molten metal.
- Improved fatigue life.
- Pouring temperature without booster pack is 48° F to 110° F.
- One booster pack if pouring temperature is 35° F to 48° F.
- Two booster packs if pouring temperature is 27° F to 35° F.
- Refer to Wirelock® Technical Manual for more information.

Note: For use on 416 & 417 Spelter Sockets Only.

Amount of Wirelock® Required			
Wire Rope Size (in.)	Wirelock® Required (cc)	Wire Rope Size (in.)	Wirelock® Required (cc)
1/4	9	1-3/4	1265
5/16	17	1-7/8	700
3/8	17	2	1265
7/16	35	2-1/8	1265
1/2	35	2-1/4	1410
9/16	52	2-3/8	1410
5/8	52	2-1/2	1830
3/4	86	2-5/8	1830
7/8	125	2-3/4	2250
1	160	3	3160
1-1/8	210	3-1/4	3795
1-1/4	350	3-1/2	4920
1-3/8	350	3-3/4	5980
1-1/2	420	4	7730
1-5/8	495		

W416-7 Kits				Booster Pack Stock No.
Kit Size	Kits Per Case	Stock No.	Wt. Each (lbs.)	
100 CC	20	1039602	.62	1039603
250 CC	12	1039604	1.25	1039605
500 CC	12	1039606	2.54	1039607
1000 CC	12	1039608	4.59	1039609
2000 CC	12	1039610	9.00	1039611

NATO Numbers:
 100cc 8030-21-902-1823
 250cc 8030-21-902-1824
 500cc 8030-21-902-1825
 1,000cc 8030-21-902-1826

Witnessed and tested by American Bureau of Shipping (ABS)

Approximate U.S. Measurements:
 250cc's Kit 1 Cup
 500cc's Kit 1 Pint
 1,000cc's Kit 1 Quart

Wire Rope Assembly & Fittings

Swaged Sockets

Swaged Sockets Assemblies

Indicate choice of end fittings on purchase orders by the suffixes "OS" or "CS" after the stock number, for open or closed type fittings. Pins and cotters are supplied as standard on open fittings, but assemblies may be specified without pins. Fittings will be assembled in the same plane unless specified otherwise on the order.

In mechanically swaged fittings, high pressure presses and precision dies cause metal of the socket to flow around wires and strands to offer the ultimate in compactness and strength with minimum weight. Material is weldless, drop-forged steel. Normally, only regular lay rope is used. Swaged assemblies are interchangeable with poured sockets up through 2" rope diameters. Assembly length is measured from centerline of pins for both open and closed sockets.

* These sockets are not interchangeable with zinc poured sockets.

Rope Dia.	Open Socket Diameter (in)								Closed Socket Diameter (in)				
	C	D	E	F	PIN	A _s	L _s (Approx.)	C	D	E	A _s	L _s (Approx.)	
1/4	11/16	5/16	1-1/2	1-3/8	.688	.438	4-7/16	1-7/16	.750	1/2	.438	3-15/16	
5/16	13/16	13/32	1-3/4	1-5/8	.812	.688	5-15/16	1-11/16	.875	11/16	.688	5-1/8	
3/8	13/16	13/32	1-3/4	1-5/8	.812	.688	5-15/16	1-11/16	.875	11/16	.688	5-1/8	
7/16	1	1/2	2	2	1.00	.875	7-5/8	2	1.063	7/8	.875	6-5/8	
1/2	1	1/2	2	2	1.00	.875	7-5/8	2	1.063	7/8	.875	6-5/8	
9/16	1-1/4	5/8	2-1/4	2-1/2	1.19	1.125	9-3/16	2-1/2	1.250	1-1/8	1.125	8-5/16	
5/8	1-1/4	5/8	2-1/4	2-1/2	1.19	1.125	9-3/16	2-1/2	1.250	1-1/8	1.125	8-5/16	
3/4	1-1/2	3/4	2-3/4	3	1.38	1.375	11-1/4	3	1.438	1-5/16	1.375	9-15/16	
7/8	1-3/4	15/16	3-1/4	3-3/8	1.63	1.50	13-1/8	3-1/2	1.688	1-1/2	1.50	11-5/8	
1	2	1-1/32	3-3/4	4	2.00	1.75	15-1/16	4	2.063	1-3/4	1.75	13-3/16	
1-1/8	2-1/4	1-3/16	4-1/4	4-1/2	2.25	2.00	16-15/16	4-1/2	2.313	2	2.00	14-11/16	
1-1/4	2-1/2	1-3/16	4-3/4	5	2.50	2.25	18-5/8	5	2.563	2-1/4	2.25	16-1/2	
1-3/8	2-1/2	1-5/16	5-1/4	5-1/4	2.50	2.50	20-1/2	5-1/4	2.563	2-1/4	2.50	18-1/8	
1-1/2	3	1-7/16	5-3/4	5-3/4	2.75	2.75	22-5/16	5-1/2	2.813	2-1/2	2.75	19-9/16	
1-3/4	3-1/2	1-11/16	6-3/4	7	3.50	3.00	26	6-3/4	3.563	3	3.00	23	
2	4	1-13/16	8	8	3.75	3.50	30-1/8	7-3/4	3.813	3-1/4	3.50	26-7/16	
2-1/4*	4-1/4	2-1/8	6-3/4	8-3/4	4.25	4.00	31-1/4	8-3/4	4.312	4	4.00	28-1/2	
2-1/2*	4-1/4	2-1/8	6-3/4	8-3/4	4.25	4.40	33-3/8	8-3/4	4.312	4	4.40	30-1/4	

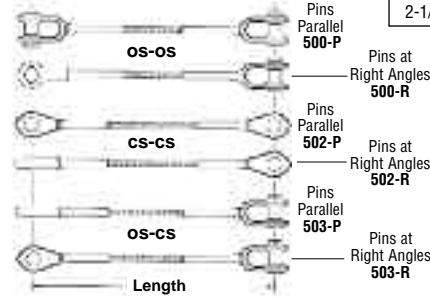
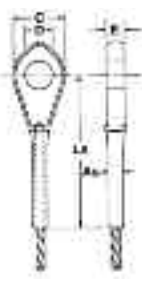
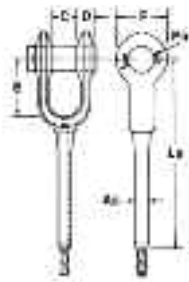

Rope Dia.	Capacity (Tons*)	
	6x19 & 6x37 IWRC	
	IPS	XIP
1/4	.588	.69
5/16	.916	1.05
3/8	1.3	1.5
7/16	1.778	2.04
1/2	2.3	2.66
9/16	2.9	3.36
5/8	3.58	4.12
3/4	5.12	5.88
7/8	6.92	7.96
1	8.98	10.34
1-1/8	11.3	13
1-1/4	13.88	15.98
1-3/8	16.7	19.2
1-1/2	19.78	22.8
1-3/4	26.6	30.6
2	34.4	39.6
2-1/4	43.	49.4
2-1/2	52.4	60.4

3 Wire Rope Assembly and Fittings

Open Swage Sockets S-501 Crosby

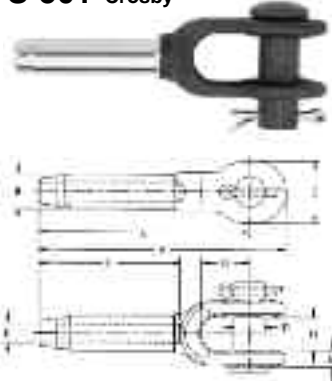

- Forged from special bar quality carbon steel, suitable for cold forming.
- Hardness controlled by spheroidize annealing.
- Swage Socket terminations have an efficiency rating of 100% based on the catalog strength of wire rope.
- Stamp for identification after swaging without concern for fractures (as per directions in National Swaging Brochure).

Stock No.	Rope Size (in.)	Wt. Each (lbs.)	Before Swage Dimensions											Max. After Swage Dim. (in.)
			A	B	C	D	E	F	H	L	M	N		
1039021	1/4	.52	4.81	.50	1.38	.69	.27	2.13	.69	4.00	.38	1.50	.46	
1039049	5/16	1.12	6.25	.77	1.62	.81	.34	3.19	.81	5.31	.47	1.75	.71	
1039067	3/8	1.30	6.25	.77	1.62	.81	.41	3.19	.81	5.31	.47	1.75	.71	
1039085	7/16	2.08	7.81	.98	2.00	1.00	.48	4.25	1.00	6.69	.56	2.00	.91	
1039101	1/2	2.08	7.81	.98	2.00	1.00	.55	4.25	1.00	6.69	.56	2.00	.91	
1039129	9/16	4.67	9.50	1.25	2.38	1.19	.61	5.31	1.25	8.13	.68	2.25	1.16	
1039147	5/8	4.51	9.50	1.25	2.38	1.19	.67	5.31	1.25	8.13	.68	2.25	1.16	
1039165	3/4	7.97	11.56	1.55	2.75	1.38	.80	6.38	1.50	10.00	.78	2.75	1.42	
1039183	7/8	11.52	13.41	1.70	3.13	1.62	.94	7.44	1.75	11.63	.94	3.25	1.55	
1039209	1	17.80	15.47	1.98	3.69	2.00	1.06	8.50	2.00	13.38	1.06	3.75	1.80	
1039227	1-1/8	25.25	17.31	2.25	4.06	2.25	1.19	9.56	2.25	15.00	1.19	4.25	2.05	
1039245	1-1/4	35.56	19.06	2.53	4.50	2.50	1.33	10.63	2.50	16.50	1.22	4.75	2.30	
1039263	1-3/8	43.75	20.94	2.80	5.00	2.50	1.45	11.69	2.50	18.13	1.38	5.25	2.56	
1039281	1-1/2	58.50	22.88	3.08	5.50	2.75	1.58	12.75	3.00	19.75	1.69	5.75	2.81	
1039307	1-3/4	88.75	26.63	3.39	6.69	3.50	1.86	14.88	3.50	23.00	2.11	6.75	3.06	
1042767	2	146.25	31.44	3.94	8.00	3.75	2.11	17.00	4.00	26.88	2.37	8.00	3.56	

Maximum Proof Load shall not exceed 40% of XXIP rope catalog breaking strength.

NOTE: S-501 Swage Sockets are recommended for use with 6 x 19 or 6 x 37, IPS or XIP (EIP), XXIP (EEIP), RRL, FC or IWRC wire rope.

In accordance with ANSI B30.9, all slings terminated with swage sockets shall be proof loaded.*

Closed Swage Sockets S-502 Crosby



- Forged from special bar quality carbon steel, suitable for cold forming.
- Hardness controlled by spheroidize annealing.
- Swage Socket terminations have an efficiency rating of 100% based on the catalog strength of wire rope.
- Stamp for identification after swaging without concern for fractures (as per directions in National Swaging Brochure).

Stock No.	Rope Size (in.)	Wt. Each (lbs.)	Before Swage Dimensions								Max. After Swage Dim. (in.)
			A	B	C	D	E	F	H	L	
1039325	1/4	.33	4.31	.50	1.38	.75	.27	2.12	.50	3.50	.46
1039343	5/16	.75	5.44	.77	1.62	.88	.34	3.19	.67	4.50	.71
1039361	3/8	.72	5.44	.77	1.62	.88	.41	3.19	.67	4.50	.71
1039389	7/16	1.42	6.91	.98	2.00	1.06	.48	4.25	.86	5.75	.91
1039405	1/2	1.42	6.91	.98	2.00	1.06	.55	4.25	.86	5.75	.91
1039423	9/16	2.92	8.66	1.25	2.38	1.25	.61	5.31	1.13	7.25	1.16
1039441	5/8	2.85	8.66	1.25	2.38	1.25	.67	5.31	1.13	7.25	1.16
1039469	3/4	5.00	10.28	1.55	2.88	1.44	.80	6.38	1.31	8.63	1.42
1039487	7/8	6.80	11.94	1.70	3.12	1.69	.94	7.44	1.50	10.13	1.55
1039502	1	10.40	13.56	1.98	3.63	2.06	1.06	8.50	1.75	11.50	1.80
1039520	1-1/8	14.82	15.03	2.25	4.00	2.31	1.19	9.56	2.00	12.75	2.05
1039548	1-1/4	21.57	16.94	2.53	4.50	2.56	1.33	10.63	2.25	14.38	2.30
1039566	1-3/8	28.54	18.63	2.80	5.00	2.56	1.45	11.69	2.25	15.75	2.56
1039584	1-1/2	38.06	20.12	3.08	5.50	2.81	1.58	12.75	2.50	17.00	2.81
1039600	1-3/4	51.00	23.56	3.39	6.25	3.56	1.86	14.88	3.00	20.00	3.06
1042589	2	89.25	27.62	3.94	7.25	3.81	2.11	17.00	3.25	23.00	3.56

Maximum Proof Load shall not exceed 40% of XXIP rope catalog breaking strength.

NOTE: S-502 Swage Sockets are recommended for use with 6 x 19 or 6 x 37, IPS or XIP (EIP), XXIP (EEIP), RRL, FC or IWRC wire rope.

In accordance with ANSI B30.9, all slings terminated with swage sockets shall be proof loaded.*

Wire Rope Assembly & Fittings

Swaged Sockets & Fittings

Open Swage Sockets Cast Stainless Steel

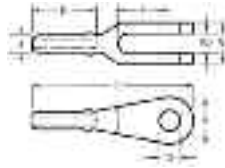

Rope Size (in.)	Socket Wt. (lbs)	Pin Wt. (lbs)	Pin Die. (in)	A (in)	B1 (in)	B2 (in)	Overall Length C (in)	Pin Hole D (in)	E* (in)	F (in)	Die Descrip. (in)
5/16	1-1/8	1/2	13/16	1-11/16	1-5/8	13/16	6	7/8	2-1/2	1-3/4	3/8 OC
3/8	1-1/8	1/2	13/16	1-11/16	1-5/8	13/16	6	7/8	2-1/2	1-3/4	3/8 OC
7/16	2-1/4	3/4	1	2	2	1	7-5/16	1-1/16	3-5/16	2	1/2 OC
1/2	2-1/4	3/4	1	2	2	1	7-5/16	1-1/16	3-5/16	2	1/2 OC
9/16	4	1	1-3/16	2-1/2	2-3/8	1-1/4	8-5/8	1-1/4	4-1/8	2-1/4	5/8 OC
5/8	4	1	1-3/16	2-1/2	2-3/8	1-1/4	8-5/8	1-1/4	4-1/8	2-1/4	5/8 OC
3/4	7-1/4	1-1/2	1-3/8	3	2-3/4	1-7/16	10-3/8	1-7/16	4-5/8	2-3/4	3/4 OC
7/8	9	2-1/2	1-5/8	3-1/2	3-1/4	1-3/4	12-1/2	1-11/16	5-3/4	3-1/4	3/4 OC
1	14-1/4	4-1/2	2	4	3-3/4	2	14-1/4	2-1/16	6-3/4	3-3/4	7/8 OC
1-1/8	20	6	2-1/4	4-1/2	4-1/4	2-1/4	17-7/8	2-5/16	9	4-1/4	1 OC

*E-Recommended rope insertion length. OC = open channel die.

NOTE: "Before" and "After" swage dimensions (J) are identical to the dimensions shown in the Closed Socket chart (shown below).

Closed Swage Sockets Cast Stainless Steel

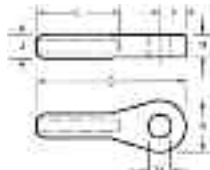

Rope Size (in)	Wt. Each (lbs)	A (in)	B (in)	Overall Length C (in)	Pin Hole D (in)	E* (in)	F (in)	Shank Dia.		Die Descrip. (in)
								Before J (in)	After J (in)	
5/16	1	1-11/16	11/16	4-5/8	7/8	2-1/2	7/8	0.88	0.759	3/8 OC
3/8	1	1-11/16	11/16	4-5/8	7/8	2-1/2	7/8	0.88	0.759	3/8 OC
7/16	1-1/2	2	13/16	5-7/8	1-1/16	3-5/16	1-1/8	1.12	1.009	1/2 OC
1/2	1-1/2	2	13/16	5-7/8	1-1/16	3-5/16	1-1/8	1.12	1.009	1/2 OC
9/16	2-1/2	2-1/2	1-1/8	7-1/4	1-1/4	4-1/8	1-3/8	1.44	1.273	5/8 OC
5/8	2-1/2	2-1/2	1-1/8	7-1/4	1-1/4	4-1/8	1-3/8	1.44	1.273	5/8 OC
3/4	3	3	1-5/16	8-3/8	1-7/16	4-5/8	1-5/8	1.72	1.530	3/4 OC
7/8	6	3-1/2	1-1/2	10-1/8	1-11/16	5-3/4	1-7/8	1.72	1.530	3/4 OC
1	10	4-1/4	1-3/4	11-9/16	2-1/16	6-3/4	2-3/16	1.97	1.760	7/8 OC
1-1/8	16	4-1/2	2	14-3/4	2-5/16	9	2-7/16	2.25	2.036	1 OC

*E-Recommended rope insertion length. OC = open channel die.

Bail Sockets Cast Stainless Steel Swage Sockets

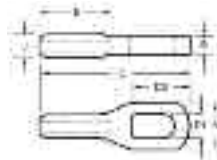

Rope Size	Wt. Each (lbs)	A	B	Length C	Hole D1	Hole D2	E*	Shank Dia.		Die Descrip.
								Before J	After J	
3/8	1	1-11/16	5/8	6-1/16	15/16	2-1/8	2-1/2	0.88	0.759	3/8 OC
7/16	1-3/4	2	7/8	7-3/8	1-1/8	2-3/8	3-5/16	1.12	1.009	1/2 OC
1/2	1-3/4	2	7/8	7-3/8	1-1/8	2-3/8	3-5/16	1.12	1.009	1/2 OC

*E-Recommended rope insertion length. OC = open channel die.

SWAGED FITTINGS

S-319 SWG Swageable Shank Hook

Wire Rope Size (in)	Hook Frame I.D. Code	S-319 SWG Stock No.	Wt. Ea. (lbs)
3/16	D	1053002	0.55
1/4	F	1053011	0.77
5/16	G	1053020	1.26
5/16	H	1053039	1.83
3/8	H	1053048	1.80
7/16	I	1053057	3.63
1/2	I	1053066	3.58
9/16	J	1053075	7.37
5/8	J	1053084	7.30
3/4	K	1053093	12.73
7/8	L	1053100	17.58
1	N	1053119	31.46
1-1/8	O	1053128	53.73



Jaw SW-704



Dash No.	Rope dia.	Dimensions (in)						After Swage Approx Cs
		D	E	F	G	P	As	
3	3/32	5/8	7/32	7/16	5/8	1/4	7/32	1-15/16
4	1/8	5/8	7/32	7/16	5/8	1/4	7/32	2-1/4
5	5/32	3/4	1/4	1/2	11/16	1/4	1/4	2-13/16
6	3/16	13/16	5/16	1/2	13/16	5/16	5/16	3-1/8
7	7/32	1	3/8	5/8	1	7/16	7/16	3-3/4
8	1/4	1	3/8	5/8	1	7/16	7/16	4-1/16
9	9/32	1-5/16	7/16	3/4	1-5/16	1/2	9/16	4-3/4
10	5/16	1-5/16	7/16	3/4	1-5/16	1/2	9/16	5-1/16
12	3/8	1-1/2	7/16	15/16	1-5/8	5/8	5/8	6
14	7/16	1-3/4	1/2	1-1/16	1-3/4	3/4	3/4	7
16	1/2	2	5/8	1-3/16	2-1/8	1	7/8	8-1/16
18	9/16	2	5/8	1-3/16	2-1/8	1	7/8	8-5/8
20	5/8	2-7/16	7/8	1-3/4	2-7/8	1-1/8	1-1/8	10-3/8
24	3/4	2-13/16	1-1/16	2-3/16	3-1/8	1-3/8	1-1/4	11-3/4

You can use the Tuf-Grip SW-704 Jaw two ways. One, with the Tuf-Grip SW-703 Pineye when you

need multiple lengths of assemblies. And two, for single lug attachment of a wire rope assembly.

Our Jaw offers excellent pin bearing surface for your applications. You can also depend on long life with its rugged, one-piece, drop-forged steel construction. Measure the length of the assembly from the center of the pin.

We supply the Tuf-Grip Jaw without a pin or a nut and bolt but we can provide either if you specify on your order.

Pineye SW-703



Dash No.	Rope dia.	Dimensions (in)				After Swage Approx Cs
		D	E	F	As	
3	3/32	1/2	17/64	9/32	7/32	1-3/16
4	1/8	1/2	17/64	9/32	7/32	1-7/16
5	5/32	5/8	17/64	11/32	1/4	1-7/8
6	3/16	3/4	11/32	7/16	5/16	2-3/16
7	7/32	1	13/32	9/16	7/16	2-19/32
8	1/4	1	13/32	9/16	7/16	2-13/16
9	9/32	1-1/4	17/32	11/16	9/16	3-9/32
10	5/16	1-1/4	17/32	11/16	9/16	3-17/32
12	3/8	1-1/2	21/32	13/16	5/8	4-7/16
14	7/16	1-3/4	25/32	15/16	3/4	5-3/32
16	1/2	2	29/32	1-1/16	7/8	5-25/32
18	9/16	2	29/32	1-1/16	7/8	6-5/16
20	5/8	3	1-5/32	1-1/4	1-1/8	7-1/16
24	3/4	3-5/8	1-7/16	1-1/2	1-1/4	8-1/2

Ideal for clevis-type attachments. The Tuf-Grip SW-703 gives you a large pin bearing area with a durable, weldless, drop-forged steel construction. Measure the length of the assembly from the center of the pin hole.

You may specify a custom-made pin hole diameter if you wish. We can make these pineye assemblies to your custom dimensions which can be fully machined to your specific application. Please contact us with your special requirements.

Large Eye Ring SW-706



Dash No.	Rope dia.	Dimensions (in)				Approx Cs
		D	E	F	As	
3	3/32	1/2	1/4	1	7/32	1-11/16
4	1/8	1/2	1/4	1	7/32	1-15/16
5	5/32	5/8	5/16	1-1/4	1/4	2-7/16
6	3/16	3/4	3/8	1-1/2	5/16	2-15/16
7	7/32	1	1/2	2	7/16	3-5/8
8	1/4	1	1/2	2	7/16	3-15/16
9	9/32	1-1/4	5/8	2-1/2	9/16	4-5/8
10	5/16	1-1/4	5/8	2-1/2	9/16	4-7/8
12	3/8	1-1/2	3/4	3	5/8	5-7/8
14	7/16	1-3/4	7/8	3-1/2	3/4	6-7/8
16	1/2	2	1	4	7/8	7-13/16
18	9/16	2	1	4	7/8	8-7/16
20	5/8	2-1/2	1-1/4	5	1-1/8	9-3/4

Tuf-Grip large ring eyes offer many advantages for hanger-type applications. They feature a large eye opening to make attachment easy and provide a large internal bearing surface. They're made of one-piece, drop-forged steel construction. To measure the assembly length, use the distance from the bearing of the eye to the appropriate point at the other end of the assembly.

Swaged Fittings

Oval Eye SW-707



For hanger-type applications that require smaller diameter pins and a narrower profile than large ring eyes, the Tuf-Grip SW-707 Oval Eye is your best choice. These are made with one-piece, drop-forged steel for dependable service. Measure the length from the bearing of the eye.

Dash No.	Rope dia.	Dimensions (in)					Approx Cs
		D	E	F	As		
3	3/32	25/32	7/32	11/32	7/32	2-1/8	
4	1/8	25/32	7/32	11/32	7/32	2-7/16	
5	5/32	15/16	9/32	7/16	1/4	3	
6	3/16	1-1/8	11/32	17/32	5/16	3-5/8	
7	7/32	1-7/16	7/16	23/32	7/16	4-7/16	
8	1/4	1-7/16	7/16	23/32	7/16	4-23/32	
9	9/32	1-3/4	1/2	7/8	9/16	5-15/32	
10	5/16	1-3/4	1/2	7/8	9/16	5-3/4	
12	3/8	2-1/8	5/8	1	5/8	7	
14	7/16	2-3/8	3/4	1-1/4	3/4	8-3/32	
16	1/2	3	7/8	1-7/16	7/8	9-9/16	
18	9/16	3	7/8	1-7/16	7/8	10-5/32	

Standard Swaged Steel Threaded Stud - SS

Style SS Standard Swaged Steel Thread Stud (Sleeves) are machined from carbon steel specially selected for swaging. Alloy and stainless steel available upon request.

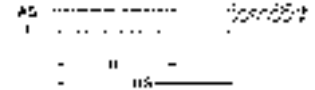

Item No. (in)	Rope Dia. (in)	AFTER SWAGE DIMENSION					Wt. (lbs)
		(AS) Dia. (in)		BS (in)	TL (lbs)		
SS-6	3/16	3/8	+00	1-3/4	1	+1/16	.050
SS-7	7/32	7/16		2	1-1/4		.087
SS-8	1/4	1/2		2	1-1/4		.175
SS-10	5/16	5/8	+00	2-1/2	1-1/2	+1/8	.313
SS-12	3/8	3/4	-015	3	1-3/4	-0	.506
SS-14	7/16	7/8		3-1/2	2		.731
SS-16	1/2	1		4	2-1/4		1.075
SS-18	9/16	1-1/8		4-1/2	2-1/2		1.475
SS-20	5/8	1-1/4	+00	5	2-3/4		2.506
SS-24	3/4	1-1/2	-020	6	3		3.981
SS-28	7/8	1-3/4		7	4		6.000
SS-32	1	2		8	5	+3/16	8.538
SS-36	1-1/8	2-1/4	+00	9	6	-0	11.725
SS-40	1-1/4	2-1/2		10	7		20.250
SS-44	1-3/8	2-3/4	-025	11	8		
SS-48	1-1/2	3		12	9		

Threaded Studs - TTS

Style TTS Threaded Studs are machined from carbon steel specially selected for swaging. Alloy and stainless steel available upon request.

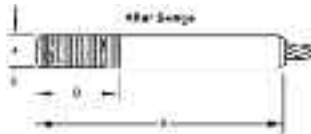

Item No.	Rope Dia. (in)	A After Swage (in)	B Approx. (in)	C (in)	E			Wt. (lbs)
					Size (in)	NC (in)	NF (in)	
TTS-8-A	1/4	1/2	4-23/32	1-1/2	1/2	13	20	.213
TTS-8	1/4	9/16	4-23/32	1-1/2	9/16	12	18	.281
TTS-10	5/16	5/8	5-23/32	1-3/4	5/8	11	18	.413
TTS-12	3/8	3/4	6-3/4	2	3/4	10	16	.719
TTS-14	7/16	7/8	7-21/32	2-1/4	7/8	9	14	1.125
TTS-16	1/2	1	8-9/16	2-1/2	1	8	14	1.644
TTS-18	9/16	1-1/8	9-5/8	2-3/4	1-1/8	7	12	2.325
TTS-20	5/8	1-1/4	10-21/32	3-1/8	1-1/4	7	12	3.231
TTS-24	3/4	1-1/2	12-11/16	3-3/4	1-1/2	6	12	5.513
TTS-28	7/8	1-3/4	14-5/8	4-3/8	1-3/4	5	12	8.575
TTS-32	1	2	16-21/32	5	2	4-1/2	12	12.600
TTS-36	1-1/8	2-1/4	18-5/8	5-5/8	2-1/4	4-1/2	12	18.000
TTS-40	1-1/4	2-1/2	20-21/32	6-1/4	2-1/2	4	12	24.687
TTS-44	1-3/8	2-3/4	22-17/32	6-7/8	2-3/4	4	12	33.062
TTS-48	1-1/2	3	24-1/2	7-1/2	3	4	12	49.300

Note: Sizes for larger diameter ropes can be supplied. All Studs supplied without wrench grips unless requested. Right hand N.C. threads supplied unless otherwise specified.

Threaded Studs - STS

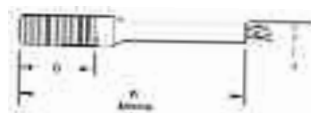

Item No.	Rope Dia. (in)	A After Swage (in)	B (in)	C (in)	N.C. THD (in)	N.F. THD (in)	Items. No.	Wt. (lbs)
STS-4	1/8	7/32	2-3/8	1	1/4 - 20	1/4 - 28	STS-4	.025
STS-6	3/16	5/16	3	1-1/8	3/8 - 16	3/8 - 24	STS-6	.069
STS-8	1/4	7/16	4-1/16	1-1/2	1/2 - 13	1/2 - 20	STS-8	.162
STS-10	5/16	9/16	5-1/16	1-7/8	5/8 - 11	5/8 - 18	STS-10	.331
STS-12	3/8	5/8	6-1/4	2-1/4	3/4 - 10	3/4 - 16	STS-12	.575
STS-14	7/16	3/4	7-5/16	2-5/8	7/8 - 9	7/8 - 14	STS-14	.900
STS-16	1/2	7/8	8-1/4	3	1 - 8	1 - 14	STS-16	1.362
STS-18	9/16	1	9-1/4	3-3/8	1-1/8 - 7	1-1/8 - 12	STS-18	1.931
STS-20	5/8	1-1/8	10-1/8	3-3/4	1-1/4 - 7	1-1/4 - 12	STS-20	2.662
STS-24	3/4	1-1/4	12-13/16	4-1/2	1-1/2 - 6	1-1/2 - 12	STS-24	4.556
STS-28	7/8	1-1/2	14-9/16	5-1/4	1-3/4 - 5	1-3/4 - 12	STS-28	7.137
STS-32	1	1-3/4	16-1/4	6	2 - 4-1/2	2 - 12	STS-32	10.662
STS-36	1-1/8	2	18-1/4	6-3/4	2-1/4 - 4-1/2	2-1/4 - 12	STS-36	15.625
STS-40	1-1/4	2-1/4	20-1/4	7-1/2	2-1/2 - 4	2-1/2 - 12	STS-40	21.000
STS-44	1-3/8	2-3/8	22-7/8	8-1/4	2-3/4 - 4	2-3/4 - 12	STS-44	30.500
STS-48	1-1/2	2-5/8	24-3/4	9	3 - 4	3 - 12	STS-48	41.100

Swage Fittings

"Cold Tuff" Button S-409

- Special processed, low carbon steel.
- "Cold Tuff" for better swageability.
- Swage Button terminations have an efficiency rating of 98% based on the catalog strength of wire rope.
- Stamp for identification after swaging without concern for fractures (as per directions in National Swaging Brochure).

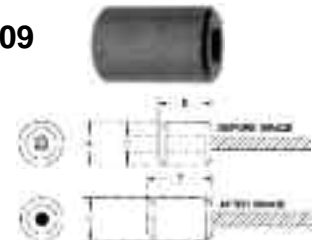

NOTE: S-409 Buttons are recommended for use with 6 x 19 or 6 x 37, IPS or XIP (EIP), RRL, FC or IWRC wire rope.

Size No.	Stock No.	Rope (in.)	Wt. Per 100 Pcs. (lbs.)	Before Swage Dim.			After Swage Dim.	
				A	B	C	D Max. After Swage Dim.	E Length
1 SB	1040171	1/8	2	.44	.50	.14	.40	.61
3 SB	1040215	3/16	4	.56	.70	.20	.52	.84
5 SB	1040251	1/4	8	.63	1.06	.30	.58	1.20
7 SB	1040297	5/16	16	.88	1.13	.36	.77	1.33
8 SB	1040313	3/8	15	.88	1.48	.42	.77	1.69
9 SB	1040331	7/16	30	1.13	1.63	.48	1.03	1.94
10 SB	1040359	1/2	50	1.31	1.89	.55	1.16	2.17
11 SB	1040377	9/16	70	1.44	2.02	.61	1.29	2.41
12 SB	1040395	5/8	100	1.56	2.42	.67	1.42	2.89
13 SB	1040411	3/4	131	1.69	2.73	.79	1.55	3.25
14 SB	1040439	7/8	220	2.00	3.27	.94	1.80	3.86
15 SB	1040457	1	310	2.25	3.67	1.06	2.05	4.36
16 SB	1040475	1-1/8	450	2.56	4.05	1.19	2.30	4.81
17 SB	1040493	1-1/4	650	2.81	4.58	1.33	2.56	5.42

NOTE: Length is measured from outside end of termination.

Wire Rope Assembly & Fittings

Wedge Sockets

The "Terminator" Crosby's "New & Improved" Wedge Socket

US patent 5,553,360 and foreign equivalents.

- Basket is cast steel.
- Individually magnetic particle inspected.
- Pin diameter and jaw opening allows wedge and socket to be used in conjunction with open swage & spelter sockets.
- Secures the tail or "dead end" of the wire rope to the wedge, thus eliminates loss or "Punch out" of the wedge.
- Eliminates the need for an extra piece of rope, and is easily installed.
- The "TERMINATOR™" wedge eliminates the potential breaking off of the tail due to fatigue.
- The tail, which is secured by the base of the clip and the wedge, is left undeformed and available for reuse.
- Incorporates Crosby's patented QUIC-CHECK™ "Go" and "No-Go" feature cast into the wedge. The proper size rope is determined when the following criteria are met:

1. The wire rope should pass thru the "Go" hole in the wedge.
 2. The wire rope should NOT pass thru the "No-Go" hole in the wedge.
- Utilizes standard Crosby Red-U-Bolt wire rope clip.
 - Generates a minimum efficiency of 80% based on the catalog breaking strength of the wire rope.
 - Standard S-421 wedge socket can be retrofitted with the new style "TERMINATOR™" wedge.
 - Available with Bolt, Nut, and Cotter Pin.



Wire Rope Size (in.)	S-421 T Stock No. Complete Assembly*	S-421 T Weight Each (lbs.)	S-421 TW Stock No. Wedge Only	S-421 TW Weight Each (lbs.)
3/8	1035000	3.18	1035555	.50
1/2	1035009	6.15	1035564	1.05
5/8	1035018	9.70	1035573	1.79
3/4	1035027	14.50	1035582	2.60
7/8	1035036	21.50	1035591	4.02
1	1035045	30.75	1035600	5.37
1-1/8	1035054	45.30	1035609	7.84
**1-1/4	1040448	57.50	1040607	6.81

Wire Rope Dia. (in.)	Dimensions (in)														
	A	B	C	D	G	H	J†	K†	L	P	R	S	T	U	V
3/8	5.63	2.77	.81	.81	1.38	3.12	7.38	1.60	.88	1.56	.44	2.13	.44	1.25	1.38
1/2	6.81	3.55	1.00	1.00	1.62	3.85	8.75	1.21	1.06	1.94	.50	2.44	.53	1.75	1.88
5/8	8.16	4.36	1.25	1.19	2.12	4.58	10.34	1.64	1.22	2.25	.56	3.13	.69	2.00	2.19
3/4	9.78	4.81	1.50	1.38	2.44	5.37	12.03	2.17	1.40	2.62	.66	3.63	.78	2.34	2.56
7/8	11.16	4.65	1.75	1.63	2.69	6.28	14.00	2.22	1.66	3.12	.75	4.19	.88	2.69	2.94
1	12.75	5.08	2.00	2.00	2.56	7.02	15.86	2.71	2.00	3.75	.88	4.63	1.03	2.88	3.28
1-1/8	14.38	5.51	2.25	2.25	3.31	7.76	17.70	2.50	2.25	4.25	1.00	5.38	1.19	3.13	3.56
1-1/4	16.00	7.94	2.50	2.50	3.56	N/A	N/A	3.39	2.50	4.75	1.12	5.81	1.31	3.38	3.81

* Terminator Assembly includes Socket, Wedge, Pin, and Wire Rope Clip.

** 1-1/4" not available in TERMINATOR™ style.

† Nominal

‡ For intermediate wire rope sizes use next larger size socket.

Wedge Sockets: Important Safety Information

Inspection/Maintenance Safety

- Always inspect socket, wedge and pin before using.
- Do not use part showing cracks.
- Do not use modified or substitute parts.
- Repair minor nicks or gouges to socket or pin by lightly grinding until surfaces are smooth. Do not reduce original dimension more than 10%. Do not repair by welding.
- Inspect permanent assemblies annually, or more often in severe operating conditions.

Assembly Safety

- Use only with standard 6 to 8 strand wire rope of designated size. For intermediate size rope, use next larger size socket. For example: When using 9/16" diameter wire rope use a 5/8" size Wedge Socket Assembly. Welding of the tail on standard wire rope is not recommended. The tail length of the dead end should be a minimum of 6 rope diameters but not less than 6" (See Fig. 1).
- To use with Rotation Resistant wire rope (special wire rope constructions with 8 or more outer strands) ensure that the dead end is welded, brazed or seized before inserting the wire rope into the wedge socket to prevent core slippage or loss of rope lay. The tail length of the dead end should be a minimum of 20 rope diameters but not less than 6" (See Fig. 1).
- Properly match socket, wedge and clip (See Table 1) to wire rope size.
- Align live end of rope, with center line of pin. (See Fig. 1)
- Secure dead end section of rope. (See Figure 1)
- Tighten nuts on clip to recommended torque. (Table 1)
- Do not attach dead end to live end or install wedge backwards. (See Fig. 2)
- Use a hammer to seat Wedge and Rope as deep into socket as possible before applying first load.

Operating Safety

- Apply first load to fully seat the Wedge and Wire Rope in the socket. This load should be of equal or greater weight than loads expected in use.
- Efficiency rating of the Wedge Socket termination is based upon the catalog breaking strength of Wire Rope. The efficiency of a properly assembled Wedge Socket is 80%.
- During use, do not strike the dead end section with any other elements of the rigging (Called two blocking).

FIG. 1 - "Terminator" Std. Wedge Socket

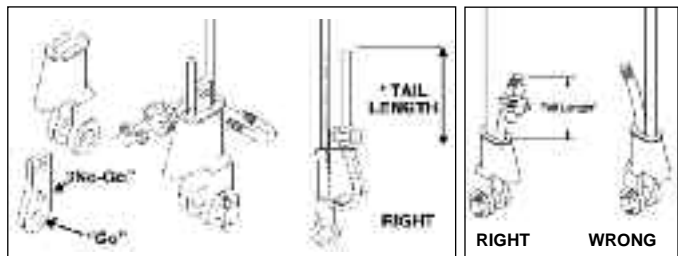

*Tail Length Standard 6 to 8 strand wire rope A min. of 6 rope diameters, but not less than 6" (i.e. - For 1" rope: Tail Length = 1" x 6 = 6")

Rotation Resistant Wire Rope A min. of 20 rope diameters, but not less than 6" (i.e. - For 1" rope: Tail Length = 1" x 20 = 20)

Rope Size	3/8	7/16	1/2	9/16	5/8	3/4	7/8	1	1-1/8	1-1/4
Clip Size	3/8	7/16	1/2	9/16	5/8	3/4	7/8	1	1-1/8	1-1/4
*Torque Ft./lbs.	45	65	65	95	95	130	225	225	225	360

* The tightening torque values shown are based upon the threads being clean, dry, and free of lubrication.

! WARNING !

FIG. 2 - "Terminator" Std. Wedge Socket

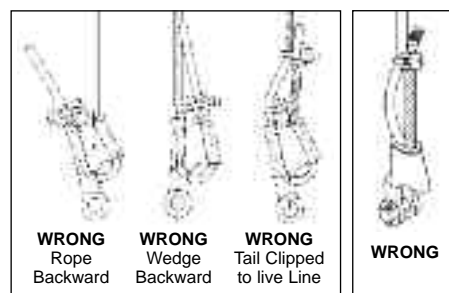

- Loads may slip or fall if the Wedge Socket is not properly installed.
- A falling load can seriously injure or kill.
- Read and understand these instructions before installing the Wedge Socket.
- Do not side load the Wedge Socket.
- Apply first load to fully seat the Wedge and Wire Rope in the socket. This load should be of equal or greater weight than loads expected in use.

Wire Rope Assembly & Fittings

Wedge Sockets/Ferrules

Pins for Open Wedge Sockets

Pins listed are standard and in stock; pins with two cotter keys or with square or hex machine bolts and nuts are also available.



Part No.	Description (in)	Wt (lbs)
P-5814	For 3/8 and 1/2 standard sockets	.6
P-5837	For 3/8 and 1/2 heavy, 5/8 and 3/4 standard skts.	1.25
P-5839	For 5/8 heavy socket	1.5
P-5871	For 3/4 heavy socket	3.
P-59021	For 7/8 and 1 heavy sockets	5.
P-58611	For 7/8, 1 and 1-1/8 std. sockets	2.5
P-59021	For 1-1/4 and 1-3/8 std. sockets	5.
P-59716	For 1-1/2, 1-5/8, 1-3/4 and 2 std. sockets	15.

Super Terminator™ Wedge Socket

Wedge socket terminations have a minimum efficiency rating on most high performance, high strength, compacted strand, rotation resistant wire ropes of 80% based on the catalog breaking strength of the various ropes.**

- Patent Pending design eliminates the difficulty of installing high performance wire rope into a wedge socket termination.
- Proper application of the Super TERMINATOR™ eliminates the "first load" requirement of conventional wedge socket terminations.
- S-423TW Wedge Kit can be retrofitted onto existing Crosby S-421T TERMINATOR™ wedge sockets.
- Wedge and accessories provided with a zinc finish.
- Meets the performance requirements of EN13411-6:2003.
- Meets or exceeds all requirements of ASME B30.26 including identification, ductility, design factor, proof load and temperature requirements. Importantly, these sockets meet other critical performance requirements including fatigue life, impact properties and material traceability, not addressed by ASME B30.26.
- Basket is cast steel and individually magnetic particle inspected.
- Pin diameter and jaw opening allows wedge and socket to be used in conjunction with closed swage and spelter sockets.
- Secures the tail or "dead end" of the wire rope to the wedge, thus eliminates loss or "punch out" of the wedge.
- Eliminates the need for an extra piece of rope, and is easily installed.
- The TERMINATOR™ wedge eliminates the potential breaking off of the tail due to fatigue.
- The tail, which is secured by the base of the clip and the tension device, is left undeformed and available for reuse.
- Available with Bolt, Nut, and Cotter Pin.



Wire Rope Dia		S-423T Assembly with Round Pin and Cotter Pin				S-423TB Assembly with Bolt, Nut and Cotter Pin				S-423TW** Wedge Kit				
in	mm	S-423T Stock No	S-423T Weight Each		S-423TB Stock No	S-423TB Weight Each		S-423TW Stock No	S-423TW Weight Each		in	mm	S-423T Stock No	S-423T Weight Each
			lbs	kg		lbs	kg		lbs	kg				
5/8	14-16	1035123	12.7	5.8	1035218	13.1	5.9	1034018	5.2	2.4				
3/4	18-19	1035132	19.4	8.8	1035227	19.1	8.7	1034027	7.2	3.3				
7/8	20-22	1035141	28.8	13.1	1035236	27.8	12.6	1034036	10.3	4.7				
1	24-26	1035150	39.2	17.8	1035245	37.3	16.9	1034045	11.9	5.4				
1-1/8	28	1035169	57.1	25.9	1035254	57.9	25.9	1034054	19.9	9.0				
1-1/4	30-32	1035178	88.6	40.2	1035272	88.1	39.9	1034063	33.8	15.3				

** Kit contains Wedge, Wire Rope Clip and Bolts, Tensioner, Tensioner Bolt and Secondary Retention Wire.

Wire Rope			Dimensions															
in	mm	S-423T Stock No	A	B	C	D	E	F	G	H	J*	L	P	R	S	T	U	V
5/8	14-16	1035123	8.25	4.50	1.25	1.19	3.00	4.06	2.13	4.61	12.31	1.22	2.25	.56	3.25	.75	6.88	2.60
3/4	18-19	1035132	9.88	5.20	1.50	1.38	3.25	4.81	2.44	5.37	14.69	1.40	2.62	.66	3.63	.88	7.65	3.02
7/8	20-22	1035141	11.25	5.88	1.75	1.63	3.81	5.73	2.69	6.16	16.98	1.67	3.13	.75	4.31	1.00	9.47	3.47
1	24-26	1035150	12.81	6.56	2.00	2.00	3.81	5.73	2.94	7.05	18.54	2.01	3.75	.88	4.70	1.13	10.41	3.82
1-1/8	28	1035169	14.38	6.94	2.25	2.25	4.00	6.85	3.38	7.81	21.23	2.26	4.25	1.00	5.44	1.25	11.83	4.22
1-1/4	30-32	1035178	16.34	8.63	2.62	2.50	4.50	7.76	3.57	9.38	24.10	2.34	4.50	1.06	6.62	1.38	13.87	5.82

NOTE: For intermediate wire rope sizes, use next larger size socket.
The S-423T Super TERMINATOR™ wedge is designed to be assembled only into the Crosby S-421T TERMINATOR™ socket body.
IMPORTANT: The S-423TW for sizes 5/8" through 1-1/8" (14mm through 28mm) will fit respective size standard Crosby S-421T basket. The 1-1/4" (30-32mm) S-423TW will only fit the Crosby S-421T 1-1/4" basket marked with " TERMINATOR™".

FERRULES

Pointed Zinc Ferrules

This ferrule is pointed to enable it to pass under loads. Two holes are provided for pouring socket metal.

Size	Length (in)	O.D. (in)	Hook Size	Rope Size (in)	Approx. Wt. (lbs)
Light	3-3/8	2-1/8	Light	3/4, 7/8, 1	1.2
Junior	3-5/8	2-3/8	Junior	7/8, 1, 1-1/8	1.8



How to attach zinc-type ferrules

Use socket metal, not babbitt or lead. These metals will not adhere to the wire-clean the rope thoroughly, dirty wires will pull out of socket metal.

1. Drive ferrule on cable 2 ferrule lengths from end. On fiber core rope only, cut out hemp center. Separate strands wires and straighten to form brush.
2. Clean greasy wires with gasoline or solvent—an inexpensive paint brush facilitates grease removal.
3. After drying thoroughly, drive ferrule out to end of cable and distribute wires evenly, flush with ferrule top.
4. Place mud seal around bottom of ferrule & sprinkle with sal ammoniac between strands. It will serve as a flux—Pour socket metal, filling ferrule slightly above top to allow for metal shrinkage after cooling. Metal is at correct pouring temperature when blue tinge appears on metal surface immediately after skimming.

Do not exceed the Safe Working Load.

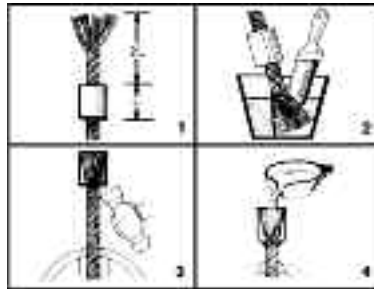

WARNING: Zinc type ferrules DO NOT develop 100% holding power (efficiency). Read and understand manufacturer's installation Instructions prior to use. Pull testing is recommended prior to use whenever the possibility of personal injury or property damage exists.

Zinc-Type Ferrules

Rugged zinc-type ferrules are made of shock and abrasion resistant alloy steel for maximum durability. These ferrules are designed to fit Bardon Hooks perfectly, insuring easy installation and trouble-free performance. Ferrules retain strength even after repeated exposure to heat. Zinc-type ferrules will not mushroom or spread.

Item	Ferrule Size Length (in)	Outside Dia. (in)	Hook Size	Rope Size (in)	Approx. Wt. (lbs)
D4	1-3/4	1-1/2	Dwarf	3/8, 1/2	.40
D5	1-3/4	1-1/2	Dwarf	5/8	.40
B4	2	1-5/8	Bantam	3/8, 1/2	.50
B5	2	1-5/8	Bantam	5/8	.50
B6	2	1-5/8	Bantam	3/4	.50
L6	2-5/8	2-1/8	Light	3/4	1.1
L7	2-5/8	2-1/8	Light	7/8	1.1
L8	2-5/8	2-1/8	Light	1	1.1
J7	2-3/4	2-3/8	Junior	7/8	1.8
J8	2-3/4	2-3/8	Junior	1	1.8
J9	2-3/4	2-3/8	Junior	1-1/8	1.8
J10	2-3/4	2-3/8	Junior	1-1/4	1.8
S9	3-3/16	2-13/16	Standard	1, 1-1/8	2.9
S10	3-3/16	2-13/16	Standard	1-1/4	2.9
S11	3-3/16	2-13/16	Standard	1-3/8	2.9
S12	3-3/16	2-13/16	Standard	1-1/2	2.9



Note: LJ Ferrule sizes have been discontinued. Use junior Ferrules on all Light Junior hooks.

Wire Rope Assembly & Fittings

Ferrules/Positive Grip Wire Rope Fittings

Wedge-Type Ferrules



1. Insert cable through the ferrule and spread the strands to insert wedge halves over the core of the wire rope.



2. Position individual strands into the proper grooves around the wedge halves and tap wedges until they are flush with strand ends.



3. Slide the ferrule back over the wedge and drive the wedge into the ferrule with a hammer and short pipe which fits inside the strands and over the core.



4. Installation is complete. The first load will seat the cable and wedge securely in the ferrule.

ESCO's machined wedge-type ferrules let you make up or repair chokers and winchlines in minutes: No molten socket metal or swaging equipment is required.

Ferrules are made of high strength alloy steel which resists splitting or cracking under severe loads. The two-piece wedges are rifled to pro-

vide more gripping surface on the wire rope strands for greater holding power.

IMPORTANT: Wedge-type ferrules are intended only for use with new 6x19 or 6x37 Class, right regular lay, EIP, IWRC or FC wire rope made to U.S. specifications.

⚠ WARNING

Strands should project above the wedge about 1/4" & should not finish below the end of the wedge.

Wedge type ferrules do not develop 100% holding power (efficiency). Read & understand manufacturer's Installation Instructions prior to use. Pull testing is recommended prior to use whenever the possibility of personal injury or property damage exists.

Rope Size (in)	Wedge Size	Ferrule Size	Color	Outside Dia. (in)	Length (in)	Wt. (lbs)
3/8, 7/16	No. 4	M3 Midget	Silver	1-1/8	1-3/8	0.25
1/2, 9/16	No. 4	M4 Midget	Lt. Blue	1-1/8	1-3/8	0.25
9/16, 5/8	No. 5	D5 Dwarf	Pink	1-1/2	1-3/4	0.5
9/16, 5/8	No. 5	B5 Bantam	Maroon	1-5/8	2	0.75
3/4	No. 6	B6 Bantam	Grey	1-5/8	2	0.75
3/4	No. 6	L6 Light	White	2-1/8	2-5/8	1.75
7/8	No. 7	L7 Light	Black	2-1/8	2-5/8	1.75
1	No. 8	L8 Light	Green	2-1/8	2-5/8	1.5
7/8	No. 7	J7 Junior	Red	2-3/8	2-3/4	2.75
1	No. 8	J8 Junior	Navy	2-3/8	2-3/4	2.0
1-1/8	No. 9	J9 Junior	Yellow	2-3/8	2-3/4	2.0
1-1/4	No. 10	J10 Junior	Orange	2-3/8	2-3/4	2.0

POSITIVE GRIP WIRE ROPE ASSEMBLIES/FITTINGS

Ordering Information for Positive Grip Fittings

ONE

Rope Size Determination

Because fittings are built to close tolerances, and to insure your complete satisfaction with the product, be certain rope sizes are correctly determined before selecting fitting sizes to match.

The correct and incorrect points for wire rope measurements are shown in these illustrations. With any type of rope, always measure at the points that will register the widest diameter.

TWO

Specify Rope Construction

Each type of rope requires a specific type of plug to insure positive grip by the fitting. Plug selection made at the factory on receipt of your order specifying rope construction. There is also a chart in this catalog of the most common wire rope plugs. As a guide, here is a listing of some of the common rope constructions:

Wire Rope

6 x 19, 8 x 19, etc.

Independent Wire Rope Core (IWRC) or Hemp Center (HC), Fiber Center (FC)

Synthetic Rope

Braided (single or double) Plaited or three strand, Jacketed, and Contrahelical

Electro-Mechanical (Conductor Core)

Armor wire diameters

Core diameter

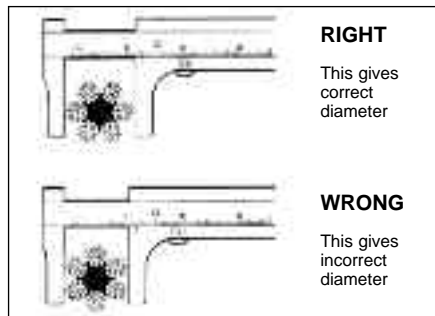

THREE

Specify Material

Wire Rope • IPS, EIP, EEIP, etc.

Synthetic Rope Nylon, Polyester, Fiberglass, Kevlar, Technora, etc.

FOUR

Machined vs. Forged Fittings

Standard forged-steel clevis and oval eye fittings are used where extra strength is required.

Rated at 2 times the rated breaking strength of I.P. rope, these fittings are available unplated or galvanized. Other steel forged fittings are rated higher than I.P. rope.

Forging tolerances may vary slightly from dimensions listed in this catalog. Please contact the factory for dimensions requiring close tolerances.

Machined fittings, available in carbon steel, stainless, aluminum and bronze, are rated at 1.3 times the rated breaking strength of the I.P. rope and provide finer adjustment, better aesthetics and corrosion resistance.

NOTE: Stainless, with its lower yield strength, may deform at lower loads than steel fittings.

FIVE

Plating

Steel fittings are manufactured with a variety of finishes. It is important to specify the finish desired by means of the suffix or last letter of the part number.

For example:

N • Natural finish, no plating

V • Zinc electroplated

X • Hot dipped galvanized

NOTE: All sleeves will be zinc electroplated where the assembly plating is specified "X".

Wire Rope Assembly & Fittings

Positive Grip Wire Rope Assemblies & Fittings

Typical Wire Rope Fitting Assembly

These fittings are the first real advance in connecting practices since the development of wire rope. These fittings are remarkably compact assemblies of three basic units:

1. The SLEEVE, which slips over the end of the rope.
2. The PLUG, which is inserted to separate and hold the rope strands in the sleeve.
3. The covering SOCKET

The combination of these three units literally locks the rope into a strong, solid assembly.

SAFE WORKING LOADS

These terminations, when properly assembled, will hold the "normal" or "rated" breaking strength of IPS wire rope. They are certified by the "Underwriters Laboratory, Inc." (Safety Appliance No. 799) to hold no less than 85% of the rated breaking strength of the rope. Fittings are designed for linear loads only. Terminations are NOT marked with safe working load (SWL) as the termination is a component of an assembly which includes the wire rope. Due to the many different types of ropes with which our termination may be used, the safe working load is dependent upon the type of rope and the usage. Electroline terminations are designed to have a breaking strength greater than 6 x 19 IPS IWRC wire rope of the corresponding size. Our safety factor is 1.3 for the steel machined fittings, and 2.0 for the forged steel clevis and eye assemblies. However, the rope is the weakest component of the assembly, and these safety factors cannot be used to determine the SWL of the assembly.

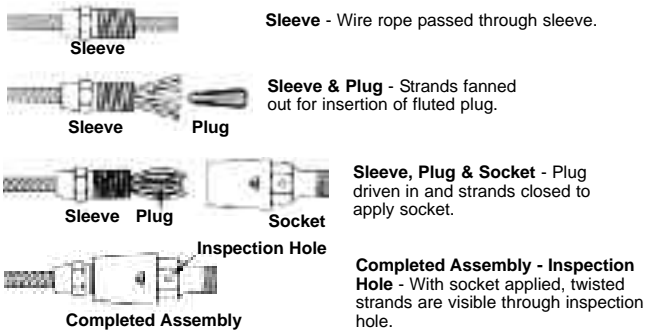
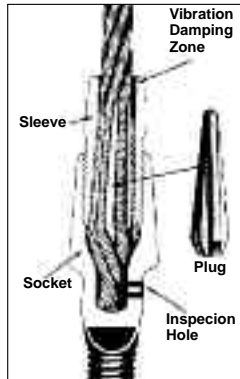

Wire Rope Assembly Kits

For easier, more efficient assembly of Wire Rope Fittings, it is suggested that assembly kits be used.

The assembly blocks prevent the wires of the rope strands from being nicked by the jaws of the vise, protect the lay of the strand, and hold all of the wires of the strand firmly so that the plug can be driven to a solid seat.

Assembly kits, as illustrated here, are available in many sizes. For ordering information, see chart.

Assembly Block

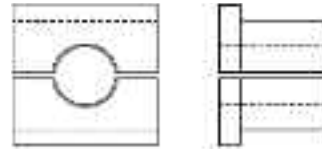

Hole Diameter is 1/32 Smaller than Cable Diameter

Rope Size (in)	Kit No.	Vise Jaws	Tube Driver
1/16 - 3/32	SP-307-D	SP-307-1D	SP-307-2AA
1/8 - 5/32	SP-307-E	SP-307-1E	SP-307-2A
3/16 - 7/32	SP-307-E	SP-307-1E	SP-307-2A
1/4 - 9/32	SP-307-G	SP-307-1F	SP-307-2A
5/16	SP-307-H	SP-307-1F	SP-307-2B
3/8	SP-307-J	SP-307-1G	SP-307-2B
7/16	SP-307-K	SP-307-1G	SP-307-2C
1/2	SP-307-L	SP-307-1H	SP-307-2C
9/16	SP-307-L	SP-307-1H	SP-307-2C
5/8	SP-307-N	SP-307-1J	SP-307-2D
3/4	SP-307-P	SP-307-1K	SP-307-2D
7/8	SP-307-Q	SP-307-1L	SP-307-2E
1	SP-307-R	SP-307-1M	SP-307-2E
1-1/8	SP-307-S	SP-307-1N	SP-307-2F
1-1/4	SP-307-T	SP-307-1P	SP-307-2F
1-3/8	SP-307-V	SP-307-1Q	SP-307-2G
1-1/2	SP-307-W	SP-307-1R	SP-307-2G



Tube Driver

3
Wire Rope Assembly and Fittings

Wire Rope Plugs

The key to the positive grip of Electroline terminations is in the plug design. Depending on the type of rope, each plug is shaped and manufactured from specific materials to maximize holding power. Plugs for the more common wire rope constructions are represented here.

However, our engineers have developed other configurations for ropes not listed. Please call, for answers to your rope termination problems.

To order a plug, first locate the vertical column, under Wire Rope Construction, that lists the TYPE of wire rope for which the replacement plug is to be used.

Second, where the row showing your rope size (in column at lower left) intersects with the rope TYPE column, the correct replacement plug for that type and size wire is listed. Please call for other rope constructions.

PLUG SELECTION TABLE									
Wire Rope Construction									
Rope Size	6 x 19 (IWRC)	6 x 21 (IWRC)	6 x 25 (IWRC)	6 x 31 (IWRC)	6 x 36 (IWRC)	6 x 37 (IWRC)	6 x 41 (IWRC)	6 x 46 (IWRC)	6 x 49 (IWRC)
	6 x 7 (HC)	6 x 19 (HC)	6 x 21 (HC)	6 x 25 (HC)	6 x 31 (HC)	6 x 36 (HC)	6 x 37 (HC)	6 x 43 (HC)	6 x 46 (HC)
	1x7 (steel only)	1 x 19	8 x 9 (HC)	8 x 25 (HC)	8 x 19 (HC)	18 x 7 (IWRC)	7 - Flex	7x7 Aircraft Cable	3x7
						19 x 19 Flex 19			3 x 37
Rope Size	Plug Catalog Number								
1/16	MB-1606	MB-1606	MB-1606	MB-1606	MB-306	MB-1606			MB-1606
3/32	MB-709	MB-1609	MB-1609	MB-309	MB-1609				
1/8	MB-712	MB-1612	MB-1612	MB-312	MB-1612	MB-312	MB-712		MB-1612
5/32	MB-715	MB-1615	MB-1615	MB-315	MB-1615	MB-315	MB-715		MB-1612
3/16	MB-718	MB-1718	MB-1518	MB-318	MB-1718	MB-318	MB-718		MB-1618
7/32	MB-721	MB-1721	MB-1521	MB-321	MB-1721	MB-321	MB-721		
1/4	MU-1925	MB-1725	MB-1525	MB-325	MB-1725	MB-2625	MB-725		MB-1618
9/32	MB-728	MB-1728	MB-1528	MB-328	MB-1728	MB-328	MB-728		
5/16	MU-1931	MB-1731	MB-1531	MB-331	MB-1831	MB-331	MB-731		MB-1625
3/8	MU-1937	MZ-1737	MC-1537	MB-337	MB-1837	MA-2637	MA-837	MB-737	MZ-1437
7/16	MU-1943	MZ-1743	MC-1543	MB-343	MZ-1843	MA-2643	MA-843	MB-743	MZ-1437
1/2	MU-1950	MZ-1750	MC-1550	MB-350	MZ-1850	MA-2650	MA-850	MB-750	MZ-1437
9/16	MZ-1956	MZ-1756	MC-1556	MB-356	MZ-1856	MA-2656	MA-856		MZ-1443
5/8	MZ-1962	MZ-1762	MC-1562	MB-362	MZ-1862	MA-2662	MA-862		MZ-1450
3/4	MZ-1975	MZ-1775	MC-1575	MB-375	MZ-1875	MA-2675	MZ-875		MZ-1462
7/8	MZ-1987	MZ-1787	MC-1587	MB-387	MZ-1887	MA-2687	MA-887		MZ-2275
1	MZ-1999	MZ-1799	MC-1599	MB-399	MZ-1899	MA-2699	MA-899		MZ-2275
1-1/8	MZ-19112	MZ-17112		MC-15112-19	MZ-18112	MA-26112	MA-8112		
1-1/4	MZ-19125	MZ-17125		MC-15125-19	MZ-18125	MA-26125			
1-3/8	MZ-19137	MZ-17137		MC-15137-19		MA-26137			
1-1/2	MZ-19150	MZ-17150		MC-15150-19		MA-26150			

A Series Plugs

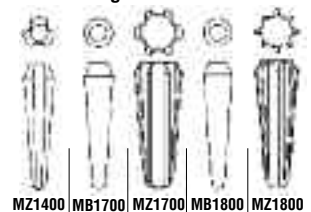

B Series Plugs

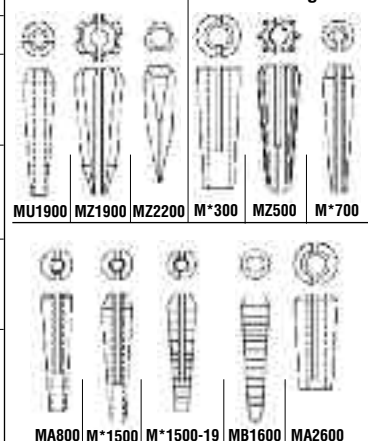

Wire Rope Assembly & Fittings

Positive Grip Fittings

EYE ASSEMBLIES

**Forged Series:
Eye Socket Assembly**

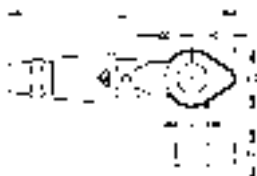

Rope Size (in)	Catalog Numbers		Dimensions (in)					
	Self-Colored Steel	Galv Steel	A	B	C	D	E	F
1/4	GD-225-N	GD-225-X	13/16	1-3/16	4-3/8	1-5/32	1/2	17/32
5/16	GD-231-N	GD-231-X	1-1/16	1-3/8	5-3/8	1-5/16	9/16	19/32
3/8	GD-237-N	GD-237-X	1-1/16	1-3/8	5-1/2	1-5/16	9/16	21/32
7/16	GD-243-N	GD-243-X	1-5/16	1-11/16	6-7/8	1-3/4	3/4	25/32
1/2	GD-250-N	GD-250-X	1-5/16	1-11/16	6-7/8	1-3/4	3/4	29/32
9/16	GD-256-N	GD-256-X	1-11/16	2-3/8	9-1/2	2-1/4	1-1/16	1-5/32
5/8	GD-262-N	GD-262-X	1-11/16	2-3/8	9-1/2	2-1/4	1-1/16	1-5/32
3/4	GD-275-N	GD-275-X	1-11/16	2-3/8	9-1/2	2-1/4	1-1/16	1-5/32
7/8	GD-287-N	GD-287-X	1-7/8	2-13/16	11-1/8	2-5/8	1-5/16	1-9/32
1	GD-299-N	GD-299-X	2-1/4	3-1/4	12-7/8	3	1-9/16	1-17/32

**Machined Series:
Eye Socket Assembly**

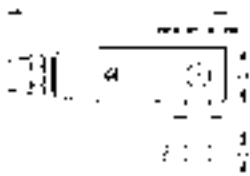

Rope Size (in)	Catalog Numbers				Dimensions (in)					
	Self-Colored Steel	Zinc Plated Steel	Stainless Steel	Bronze	A	B	C	D	E	F
1/16	ID-206-N	ID-206-V	IS-206	IZ-206	9/32	9/32	2-1/16	1/2	11/64	13/64
3/32	ID-209-N	ID-209-V	IS-209	IZ-209	11/32	7/16	2-15/32	3/8	15/64	13/64
1/8	ID-212-N	ID-212-V	IS-212	IZ-212	11/32	7/16	2-15/32	5/8	15/64	17/64
5/32	ID-215-N	ID-215-V	IS-215	IZ-215	13/32	9/16	3	3/4	19/64	21/64
3/16	ID-218-N	ID-218-V	IS-218	IZ-218	13/32	9/16	3	3/4	19/64	21/64
7/32	ID-221-N	ID-221-V	IS-221	IZ-221	1/2	13/16	3-3/4	15/16	23/64	21/64
1/4	ID-225-N	ID-225-V	IS-225	IZ-225	1/2	13/16	3-3/4	15/16	23/64	25/64
9/32	ID-228-N	ID-228-V	IS-228	IZ-228	19/32	27/32	4-9/32	1-1/16	23/64	29/64
5/16	ID-231-N	ID-231-V	IS-231	IZ-231	19/32	27/32	4-9/32	1-1/16	23/64	29/64
3/8	ID-237-N	ID-237-V	IS-237	IZ-237	21/32	29/32	4-7/8	1-3/16	27/64	33/64
7/16	ID-243-N	ID-243-V	IS-243	IZ-243	3/4	1-1/32	5-21/32	1-3/8	27/64	41/64
1/2	ID-250-N	ID-250-V	IS-250	IZ-250	27/32	1-1/8	6-3/8	1-9/16	31/64	45/64
9/16	ID-256-N	ID-256-V	IS-256	IZ-256	1-1/16	1-5/16	7-19/32	2	21/32	61/64
5/8	ID-262-N	ID-262-V	IS-262	IZ-262	1-3/32	1-5/16	7-5/8	2	21/32	61/64
3/4	ID-275-N	ID-275-V	IS-275	IZ-275	1-9/32	1-17/32	8-15/16	2-5/16	23/32	1-9/64
7/8	ID-287-N	ID-287-V	IS-287	IZ-287	1-1/2	1-5/8	11-1/8	2-5/8	25/32	1-17/64
1	ID-299-N	ID-299-V	IS-299	IZ-299	1-13/16	2	13-1/8	3	29/32	1-33/64

**Forged Series:
Oval Eye Socket Assembly**

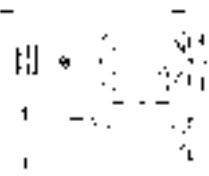

Rope Size (in)	Catalog Numbers		Dimensions (in)					
	Self-Colored Steel	Galv. Steel	A	B	C	D	E	F
1/4	X-3325-N	X-3325-X	7/8	1-15/16	1-3/4	5/8	5-1/2	1-1/8
5/16	X-3331-N	X-3331-X	7/8	1-15/16	1-3/4	5/8	5-11/16	1-1/8
3/8	X-3337-N	X-3337-X	7/8	1-15/16	1-3/4	5/8	5-13/16	1-1/8
7/16	X-3343-N	X-3343-X	1	2-1/16	2-1/8	7/8	6-7/8	1-1/2
1/2	X-3350-N	X-3350-X	1	2-1/16	2-1/8	7/8	6-7/8	1-1/2
9/16	X-3356-N	X-3356-X	1-5/8	3-5/8	3	1-3/16	10-1/2	2-1/4
5/8	X-3362-N	X-3362-X	1-5/8	3-5/8	3	1-3/16	10-1/2	2-1/4
3/4	X-3375-N	X-3375-X	1-5/8	3-5/8	3	1-3/16	10-1/2	2-1/4
7/8	X-3387-N	X-3387-X	1-7/8	4-1/4	3-5/8	1-3/4	12-1/8	2-5/8
1	X-3399-N	X-3399-X	2-1/8	4-3/4	4	1-3/4	14	3
1-1/8	X-33112-N	X-33112-X	2-5/8	5-15/16	4-7/8	2-1/4	18-1/2	3-11/16
1-1/4	X-33125-N	X-33125-X	2-5/8	5-15/16	4-7/8	2-1/4	19-1/16	3-11/16

Drum Socket Assembly

Rope Size (in)	Catalog Numbers		Dimensions (in)		
	Self-Colored Steel	Zinc Plated Steel	A	B	C
1/16	Y-2206-N	Y-2206-V	1-5/16	7/16	1/2
3/32	Y-2209-N	Y-2209-V	1-9/16	9/16	21/32
1/8	Y-2212-N	Y-2212-V	1-9/16	9/16	21/32
5/32	Y-2215-N	Y-2215-V	1-15/16	5/8	23/32
3/16	Y-2218-N	Y-2218-V	1-15/16	5/8	23/32
1/4	Y-2225-N	Y-2225-V	1-15/16	3/4	7/8
5/16	Y-2231-N	Y-2231-V	2-3/8	7/8	1
3/8	Y-2237-N	Y-2237-V	2-3/4	15/16	1-3/32
7/16	Y-2243-N	Y-2243-V	3-1/4	1-1/8	1-5/16
1/2	Y-2250-N	Y-2250-V	3-3/4	1-1/4	1-7/16
9/16	Y-2256-N	Y-2256-V	4-3/8	1-9/16	1-13/16
5/8	Y-2262-N	Y-2262-V	4-3/8	1-9/16	1-13/16
3/4	Y-2275-N	Y-2275-V	5-1/8	1-13/16	2-3/32
7/8	Y-2287-N	Y-2287-V	6	2-1/8	2-15/32
1	Y-2299-N	Y-2299-V	7	2-1/2	2-7/8
1-1/8	Y-22112-N	Y-22112-V	9-1/16	2-5/8	3-11/16
1-1/4	Y-22125-N	Y-22125-V	9-5/16	2-5/8	3-11/16
1-3/8	Y-22137-N	Y-22137-V	11-1/2	3-1/8	4-11/32
1-1/2	Y-22150-N	Y-22150-V	11-1/2	3-1/8	4-11/32



Coupling Assembly

Rope Size (in)	Catalog Numbers		Dimensions (in)		
	Self-Colored Steel	Zinc Plated Steel	A	B	C
1/16	GD-506-N	GD-506-V	7/16	1-3/4	2-5/8
3/32	GD-509-N	GD-509-V	9/16	2-1/8	3-1/8
1/8	GD-512-N	GD-512-V	9/16	2-1/8	3-1/8
5/32	GD-515-N	GD-515-V	5/8	2-7/16	3-11/16
3/16	GD-518-N	GD-518-V	5/8	2-7/16	3-11/16
7/32	GD-521-N	GD-521-V	3/4	2-11/16	4-9/16
1/4	GD-525-N	GD-525-V	3/4	2-11/16	4-9/16
9/32	GD-528-N	GD-528-V	7/8	3-11/32	5-7/16
5/16	GD-531-N	GD-531-V	7/8	3-11/32	5-7/16
3/8	GD-537-N	GD-537-V	15/16	3-13/16	6-3/16
7/16	GD-543-N	GD-543-V	1-1/8	4-23/32	7-1/16
1/2	GD-550-N	GD-550-V	1-1/4	5-13/32	8
9/16	GD-556-N	GD-556-V	1-9/16	6-13/32	9-3/4
5/8	GD-562-N	GD-562-V	1-9/16	6-13/32	9-3/4
3/4	GD-575-N	GD-575-V	1-13/16	7-1/2	11-3/8
7/8	GD-587-N	GD-587-V	2-1/8	8-27/32	13-3/16
1	GD-599-N	GD-599-V	2-1/2	10-15/32	15-9/16
1-1/8	GD-5112-N	GD-5112-V	3	12-1/2	19-1/4
1-1/4	GD-5125-N	GD-5125-V	3-1/2	14-1/4	22-1/2
1-3/8	GD-5137-N	GD-5137-V	4	18-7/8	29-1/8
1-1/2	GD-5150-N	GD-5150-V	4	18-7/8	29-1/8



Wire Rope Sleeves

Rope Size (in)	Sleeve Selection Table				
	Self-Colored Steel	Cad. Plated Steel	Galv. steel	Bronze	Stainless Steel
1/16	ID-906-N	ID-906-Y	ID-906-X	IZ-906	IS-906
3/32	ID-909-N	ID-909-Y	ID-909-X	IZ-909	IS-909
1/8	ID-912-N	ID-912-Y	ID-912-X	IZ-912	IS-912
5/32	ID-915-N	ID-915-Y	ID-915-X	IZ-915	IS-915
3/16	ID-918-N	ID-918-Y	ID-918-X	IZ-918	IS-918
7/32	ID-921-N	ID-921-Y	ID-921-X	IZ-921	IS-921
1/4	ID-925-N	ID-925-Y	ID-925-X	IZ-925	IS-925
9/32	ID-928-N	ID-928-Y	ID-928-X	IZ-928	IS-928
5/16	ID-931-N	ID-931-Y	ID-931-X	IZ-931	IS-931
3/8	ID-937-N	ID-937-Y	ID-937-X	IZ-937	IS-937
7/16	ID-943-N	ID-943-Y	ID-943-X	IZ-943	IS-943
1/2	ID-950-N	ID-950-Y	ID-950-X	IZ-950	IS-950
9/16	V-956-N	ID-956-Y	ID-956-X	IZ-956	IS-956
5/8	ID-962-N	ID-962-Y	ID-962-X	IZ-962	IS-962
3/4	ID-975-N	ID-975-Y	ID-975-X	IZ-975	IS-975
7/8	ID-987-N	ID-987-Y	ID-987-X	IZ-987	IS-987
1	ID-999-N	ID-999-Y	ID-999-X	IZ-999	IS-999
1-1/8	ID-9112-N	ID-9112-Y	ID-9112-X	IZ-9112	IS-9112
1-1/4	ID-9125-N	ID-9125-Y	ID-9125-X	IZ-9125	IS-9125
1-3/8	ID-9137-N	ID-9137-Y	ID-9137-X	IZ-9137	IS-9137
1-1/2	ID-9150-N	ID-9150-Y	ID-9150-X	IZ-9150	IS-9150



Wire Rope Assembly & Fittings

Positive Grip Fittings

CLEVIS ASSEMBLIES

Forged Series:
 Clevis Socket Assembly

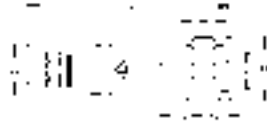

Extra Strength Series:
 Clevis Socket with Pin & Cotter Pin

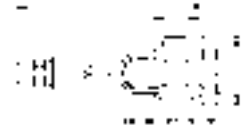

Rope Size (in)	Catalog Numbers		Dimensions (in)					
	Self-Colored Steel	Galvanized Steel	A	B	C	D	E	F
1/4	GD-125-N	GD-125-X	11/16	1-1/4	4-1/2	1-23/32	17/32	1/2
5/16	GD-131-N	GD-131-X	13/16	1-1/2	5-3/8	2-1/32	11/16	9/16
3/8	GD-137-N	GD-137-X	13/16	1-1/2	5-1/2	2-5/32	11/16	5/8
7/16	GD-143-N	GD-143-X	1-1/16	2	7-3/16	2-29/32	1	3/4
1/2	GD-150-N	GD-150-X	1-1/16	2	7-3/16	2-31/32	1	7/8
9/16	GD-156-N	GD-156-X	1-1/4	2-1/2	8-5/8	3-7/16	1-1/4	1
5/8	GD-162-N	GD-162-X	1-1/4	2-1/2	8-5/8	3-7/16	1-1/4	1
3/4	GD-175-N	GD-175-X	1-7/16	3	10-3/16	4	1-1/2	1-1/8
7/8	GD-187-N	GD-187-X	1-5/8	2-5/8	11	4-3/8	1-9/16	1-1/4
1	GD-199-N	GD-199-X	1-15/16	2-7/8	12-11/16	4-7/8	1-7/8	1-1/2
1-1/8	GD-1112-N	GD-1112-X	2-3/16	3-5/16	16-1/4	5-1/2	1-15/16	1-3/4
1-1/4	GD-1125-N	GD-1125-X	2-3/16	3-5/16	17	5-5/8	1-15/16	1-13/16

Rope Size (in)	Catalog Numbers		Dimensions (in)					
	Self-Colored Steel	Galv. Steel	A	B	C	D	E	F
7/16	PD-143-N	PD-143-X	1-1/16	2	7-3/16	2-19/32	1	1
1/2	PD-150-N	PD-150-X	1-1/16	2	7-3/16	2-19/32	1	1
9/16	PD-156-N	PD-156-X	1-1/4	2-1/2	8-5/8	3-11/64	1-1/4	1-3/16
5/8	PD-162-N	PD-162-X	1-1/4	2-1/2	8-5/8	3-11/64	1-1/4	1-3/16
3/4	PD-175-N	PD-175-X	1-7/16	3	10-3/16	3-11/16	1-1/2	1-3/8
7/8	PD-187-N	PD-187-X	1-15/16	2-7/8	12-11/16	4-7/8	1-7/8	1-1/2
1	PD-199-N	PD-199-X	2-3/16	3-5/16	17	5-5/8	1-15/16	1-13/16

NOTE: Extra Strength Fittings rated at 100% RBS of Extra-Improved Plow Steel Wire Rope. Larger Sizes Available – call for more information.

Machined Series: Clevis Socket Assembly

Rope Size (in)	Catalog Numbers				Dimensions (in)						
	Self-Colored Steel	Zinc Plated Steel	Stainless Steel	Bronze	A	B	C	D	E	F	G
1/16	ID-106-N	ID-106-V	IS-106	IZ-106	17/64	3/8	2-1/16	43/64	3/16	3/16	1/2
3/32	ID-109-N	ID-109-V	IS-109	IZ-109	5/16	1/2	2-7/16	13/16	1/4	1/4	5/8
1/8	ID-112-N	ID-112-V	IS-112	IZ-112	5/16	1/2	2-7/16	13/16	1/4	1/4	5/8
5/32	ID-115-N	ID-115-V	IS-115	IZ-115	3/8	5/8	2-31/32	63/64	5/16	5/16	3/4
3/16	ID-118-N	ID-118-V	IS-118	IZ-118	3/8	5/8	2-31/32	63/64	5/16	5/16	3/4
7/32	ID-121-N	ID-121-V	IS-121	IZ-121	15/32	3/4	3-23/32	1-9/64	3/8	3/8	15/16
1/4	ID-125-N	ID-125-V	IS-125	IZ-125	15/32	3/4	3-23/32	1-9/64	3/8	3/8	15/16
9/32	ID-128-N	ID-128-V	IS-128	IZ-128	17/32	7/8	4-1/4	1-19/64	3/8	7/16	1-1/16
5/16	ID-131-N	ID-131-V	IS-131	IZ-131	17/32	7/8	4-1/4	1-19/64	3/8	7/16	1-1/16
3/8	ID-137-N	ID-137-V	IS-137	IZ-137	5/8	1	4-27/32	1-31/64	7/16	1/2	1-3/16
7/16	ID-143-N	ID-143-V	IS-143	IZ-143	23/32	1-1/4	5-5/8	1-11/16	7/16	5/8	1-3/8
1/2	ID-150-N	ID-150-V	IS-150	IZ-150	51/64	1-3/8	6-11/32	1-59/64	1/2	11/16	1-9/16
9/16	ID-156-N	ID-156-V	IS-156	IZ-156	1-3/64	1-17/32	7-19/32	2-5/32	11/16	15/16	2
5/8	ID-162-N	ID-162-V	IS-162	IZ-162	1-3/64	1-17/32	7-19/32	2-5/32	11/16	15/16	2
3/4	ID-175-N	ID-175-V	IS-175	IZ-175	1-15/64	1-27/32	8-29/32	2-7/16	3/4	1-1/8	2-5/16
7/8	ID-187-N	ID-187-V	IS-187	IZ-187	1-7/16	1-7/8	10-3/16	2-47/64	13/16	1-1/4	2-5/8
1	ID-199-N	ID-199-V	IS-199	IZ-199	1-3/4	2-1/4	12	3-7/64	15/16	1-1/2	3

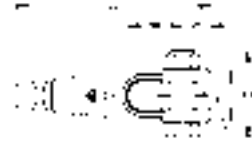

STUD ASSEMBLIES

Forged Series - Stud Socket Assembly

Rope Size (in)	Catalog Number		Dimensions (in)			
	Self-Colored Steel	Galv. Steel	A*	C	Thread	D
1/4	GD-325-N	GD-325-X	4-3/16	7-3/8	1/2-13	1
5/16	GD-331-N	GD-331-X	4-3/16	7-9/16	1/2-13	1
3/8	GD-337-N	GD-337-X	4-1/2	8-1/4	5/8-1 1	1-1/8
7/16	GD-343-N	GD-343-X	6-3/8	10-15/16	3/4-10	1-1/2
1/2	GD-350-N	GD-350-X	6-3/8	10-15/16	3/4-10	1-1/2
9/16	GD-356-N	GD-356-X	8-1/8	13-7/8	7/8-9	1-13/16
5/8	GD-362-N	GD-362-X	8-1/8	13-7/8	7/8-9	1-13/16
34	GD-375-N	GD-375-X	8-5/8	15-1/4	1-1/8-7	2-1/4
7/8	GD-387-N	GD-387-X	9	16-5/8	1-1/4-7	2-5/8
1	GD-399-N	GD-399-X	12-1/8	21-5/16	1-1/2-6	3



NOTE: *Please call for other stud dimensions.

Machined Series - Stud Socket Assembly

Rope Size (in)	Catalog Numbers			Dimensions (in)				
	Self-Colored Steel	Zinc Plated Steel	Stainless Steel	Bronze	A*	C	Thread	D
1/16	ID-306-N	ID-306-V	IS-306	IZ-306	1-19/32	3-1/32	10-32	1/2
3/32	ID-309-N	ID-309-V	IS-309	IZ-309	1-7/8	3-1/2	1/4-28	9/16
1/8	ID-312-N	ID-312-V	IS-312	IZ-312	1-7/8	3-1/2	1/4-28	9/16
5/32	ID-315-N	ID-315-V	IS-315	IZ-315	2-3/16	4-3/16	3/8-24	11/16
3/16	ID-318-N	ID-318-V	IS-318	IZ-318	2-3/16	4-3/16	3/8-24	11/16
7/32	ID-321-N	ID-321-V	IS-321	IZ-321	4-9/16	7-1/16	1/2-20	7/8
1/4	ID-325-N	ID-325-V	IS-325	IZ-325	4-9/16	7-1/16	1/2-20	7/8
9/32	ID-328-N	ID-328-V	IS-328	IZ-328	4-9/16	7-1/2	5/8-18	1
5/16	ID-331-N	ID-331-V	IS-331	IZ-331	4-9/16	7-1/2	5/8-18	1
3/8	D-337-N	ID-337-V	IS-337	IZ-337	4-15/16	8-3/16	3/4-16	1-1/8
7/16	ID-343-N	ID-343-V	IS-343	IZ-343	6-15/16	10-11/16	7/8-14	1-5/16
1/2	ID-350-N	ID-350-V	IS-350	IZ-350	6-15/16	11	7/8-14	1-1/2
9/16	ID-356-N	ID-356-V	IS-356	IZ-356	8-5/8	15-5/64	1-1/8-7	1-11/16
5/8	ID-362-N	ID-362-V	IS-362	IZ-362	8-5/8	15-5/64	1-1/8-7	1-11/16
3/4	ID-375-N	ID-375-V	IS-375	IZ-375	9-1/4	16-3/4	1-1/4-7	2
7/8	ID-387-N	ID-387-V	IS-387	IZ-387	9-3/4	18-35/64	1-1/2-6	2-1/4
1	ID-399-N	ID-399-V	IS-399	IZ-399	12-3/4	23-7/64	1-3/4-5	2-5/8
1-1/8	IGD-3112-N	IGD-3112-V	IGS-3112	IGZ-3112	13-1/8	25-1/16	1-3/4-5	3
1-1/4	IGD-3125-N	IGD-3125-V	IGS-3125	IGZ-3125	13-1/8	26-11/16	1-3/4-5	3-1/2
1-3/8	IGD-3137-N	IGD-3137-V	IGS-3137	IGZ-3137	16-5/8	34-7/16	2-4-1/2	4
1-1/2	IGD-3150-N	IGD-3150-V	IGS-3150	IGZ-3150	16-5/8	34-7/16	2-4-1/2	4

NOTE: * Please call for other stud dimensions.

Wire Rope Assembly & Fittings

Positive Grip Fittings/Swaged Fittings

TURNBUCKLES:

Forged Series: Open Body Double Clevis & Socket Turnbuckle

Rope Size (in)	Catalog Numbers		Dimensions (in)		Take-up* (in)
	Self-Colored Steel	Galv. Steel	C Min.	D	
1/4	XD-5425-AN	XD-5425-AX	14-9/16	1	6
1/4	XD-5425-BN	XD-5425-BX	17-9/16	1	9
1/4	XD-5425-CN	XD-5425-CX	20-9/16	1	12
5/16	XD-5431-AN	XD-5431-AX	15-3/8	1	6
5/16	XD-5431-BN	XD-5431-BX	18-3/8	1	9
5/16	XD-5431-CN	XD-5431-CX	21-3/8	1	12
3/8	XD-5437-AN	XD-5437-AX	19-3/4	1-1/8	6
3/8	XD-5437-BN	XD-5437-BX	19-3/4	1-1/8	9
3/8	XD-5437-CN	XD-5437-CX	22-3/4	1-1/8	12
7/16	XD-5443-AN	XD-5443-AX	17-3/4	1-1/2	6
7/16	XD-5443-BN	XD-5443-BX	20-3/4	1-1/2	9
7/16	XD-5443-CN	XD-5443-CX	23-3/4	1-1/2	12
1/2	XD-5450-AN	XD-5450-AX	19-1/4	1-1/2	6
1/2	XD-5450-BN	XD-5450-BX	22-1/4	1-1/2	9
1/2	XD-5450-CN	XD-5450-CX	25-1/4	1-1/2	12
9/16	XD-5456-CN	XD-5456-CX	27-7/8	1-13/16	12
9/16	XD-5456-DN	XD-5456-DX	33-7/8	1-13/16	18
5/8	XD-5462-CN	XD-5462-CX	27-7/8	1-13/16	12
5/8	XD-5462-DN	XD-5462-DX	33-7/8	1-13/16	18
3/4	XD-5475-CN	XD-5475-CX	33-3/8	2-5/8	12
3/4	XD-5475-DN	XD-5475-DX	39-3/8	2-5/8	18
3/4	XD-5475-EN	XD-5475-EX	45-3/8	2-5/8	24
7/8	XD-5487-CN	XD-5487-CX	33-7/8	2-5/8	12
7/8	XD-5487-DN	XD-5487-DX	39-7/8	2-5/8	18
7/8	XD-5487-EN	XD-5487-EX	45-3/8	2-5/8	24
1	XD-5499-CN	XD-5499-CX	37-1/2	3	12
1	XD-5499-DN	XD-5499-DX	43-1/2	3	18
1	XD-5499-EN	XD-5499-EX	49-1/2	3	24
1-1/8	XD-54112-DN	XD-54112-DX	51-7/8	3-11/16	18
1-1/8	XD-54112-EN	XD-54112-EX	57-7/8	3-11/16	24
1-1/4	XD-54125-DN	XD-54125-DX	51-7/8	3-11/16	18
1-1/4	XD-54125-EN	XD-54125-EX	57-7/8	3-11/16	24
1-3/8	XD-54137-EN	XD-54137-EX	66-5/8	4-11/32	24
1-1/2	XD-54150-EN	XD-54150-EX	66-5/8	4-11/32	24

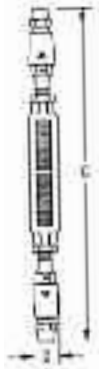

NOTE: *Please contact a representative for more information regarding longer takeup on 1-1/8" thru 1-1/2" sizes.

SWAGED FITTINGS

Oval Sleeve Finished Eye Splice Stop Sleeve Finished Stop



Copper Oval Sleeves

Cable Size (in)	Nicopress Oval Sleeve Stock No.		Nicopress Hand Tool Stock No.	Approx. Wt. Per 1000 Sleeves (lbs)	Sleeve Length Before Compressed Approx. (in)	Sleeve Length Before Compressed Approx. (in)
	Plain Copper	Zinc-Plated Copper				
1/32	17-1-B	27-1-B	*17-BA	0.6	1/4	5/16
3/64	18-11-B4	28-11-B4	51-B4-887	2	3/8	7/16
1/16	18-1-C	28-1-C	51-C-887	3	3/8	7/16
3/32	18-2-G	28-2-G	51-G-887	5	3/8	7/16
1/8	18-3-M	28-3-M	51-M-850	17	9/16	3/4
5/32	18-4-P	28-4-P	51-P-850	23	5/8	7/8
3/16	18-6-X	28-6-X	51-X-850	49	15/16	1-3/16
7/32	18-8-F2	28-8-F2	51-F2-850	56	7/8	1-1/16
1/4	18-10-F6	28-10-F6	3-F6-950	80	1-1/8	1-1/2
5/16	18-13-G9	28-13-G9	3-G9-950	114	1-1/16	1-3/8
No. 635 Hydraulic Tool Dies						
3/8	18-23-H5	28-23-H5	Oval H5	153	1-1/4	1-5/8
7/16	18-24-J8	28-24-J8	Oval J8	302	1-3/4	2-5/16
1/2	18-25-K8	28-25-K8	Oval K8	410	1-7/8	2-1/2
9/16	18-27-M1	28-27-M1	Oval M1	551	2	2-5/8
5/8	18-28-N5	28-28-N5	Oval N5	802	2-3/8	3-1/8

Copper Stop Sleeves

Cable Size (in)	Nicopress Stop Sleeve Stock No.	Nicopress Hand Tool Stock No.	Outside Dia. of Sleeves (in)	Approx. Wt. Per 1000 Sleeves (lbs)	Sleeve Length Before Compressed Approx. (in)	**Typical Holding Strength of Stop Sleeve (lbs)
1/32	871-32-B	*17-BA	1/8	3/4	1/4	120
3/64	871-12-B4	51-B4-887	11/64	1-1/2	7/32	240
1/16	871-1-C	51-C-887	13/64	2	7/32	430
1/16	***871-1-Q	51-Q-929	1/4	2	5/32	425
3/32	871-17-J (Yellow)	51-MJ	21/64	8	5/16	600
3/32	***871-3-Q	51-Q-929	1/4	2	5/32	550
1/8	871-18-J (Red)	51-MJ	21/64	8	5/16	900
5/32	871-19-M	51-MJ	27/64	13	5/16	1,200
3/16	871-20-M (Black)	51-MJ	27/64	12	5/16	1,600
7/32	871-22-M	51-MJ	7/16	20	5/8	2,500
1/4	871-23-F6	3-F6-950	21/32	60	11/16	3,500
5/16	871-26-F6	3-F6-950	21/32	60	11/16	4,000

*Formerly 17-1 Tool. **Holding strengths shown are based on use galvanized aircraft cable. ***Electro Galvanized Steel Sleeves.

Tin Plated Copper Oval Sleeves

The 428 Series oval sleeves are made from special materials and are specifically designed for use with stainless steel aircraft cable. The tin plating gives this Nicopress sleeve a distinctive appearance.

Cable Size (in)	Oval Sleeve Stock No.	Single Groove Hand Tool Stock No.	Multi-Groove Hand Tool Stock No.	No. 635 Hydraulic Tool Die	Wt. (lbs) Per 1000 Sleeves Approx.	Sleeve Length Before Compression Approx. (in)	Sleeve Length Before Compression Approx. (in)
3/64	428-1.5-VB4	51-B4-887	33V-CGB4	Oval B4	2	3/8	7/16
1/16	428-2-VC	51-C-887	33V-CGB4 64-CGMP	Oval C	3	3/8	7/16
3/32	428-3-VG	51-G-887	33V-CGB4 64-CGMP	Oval G	6	3/8	7/16
1/8	428-4-VM	51-M-850	64-CGMP 63-XPM	Oval M	17	9/16	3/4
5/32	428-5-VP	51-P-850	64-CGMP 63-XPM	Oval P	23	5/8	7/8
3/16	428-6-VX	51-X-850	63-XPM	Oval X	49	15/16	1-3/16
7/32	428-7-VF2	51-F2-850		Oval F2	59	7/8	1-1/16
1/4	428-8-VF6	3-F6-950		Oval F6	81	1	1-3/8
5/16	428-10-VG9	3-G9-950		Oval G9	120	1-1/16	1-3/8
3/8	428-12-VH5			Oval H5	155	1-3/16	1-1/2
7/16	428-14-VJ8			Oval J8	310	1-3/4	2-5/16
1/2	428-16-VK8			Oval K8	420	1-7/8	2-9/16
9/16	428-18-VM1			Oval M1	565	2	2-13/16
5/8	428-20-VN5			Oval N5	822	2-3/8	3-1/4

Copper Duplex Sleeves

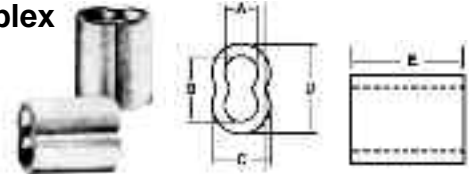

EXTRUDED COPPER DUPLEX SLEEVES, ZINC PLATED COPPER SLEEVES and COPPER BUTTONS have efficient cold forming properties, and are ideal for non-rusting permanent splices. These sleeves and buttons are 99% pure copper, and the mass of copper provides excellent holding strength.

Return eye splice using COPPER DUPLEX SLEEVES will attain 95% of Improved Plow wire rope catalog -strength when properly swaged.

CAUTION: Return eye slings using copper duplex sleeves must be properly swaged to attain strength.

Rope Size (in)	Approx. Dimensions (in)					No. Presses	After Swage O.D.	Wt. Per 100
	A	B	C	D	E			
1/32	3/64	3/32	3/32	9/64	1/4	1	.100	.045
3/64	1/16	1/8	9/64	13/64	3/8	2	.154	.2
1/16	3/32	11/64	11/64	1/4	25/64	3	.190	.3
3/32	7/64	1/4	15/64	3/8	29/64	3	.265	.65
1/8	5/32	21/64	21/64	1/2	9/16	3	.353	1.6
5/32	3/16	27/26	3/8	19/32	5/8	3	.390	2.3
3/16	7/32	7/16	7/16	43/64	7/8	4	.475	5.1
7/32	1/4	33/64	15/32	23/32	7/8	4	.510	4.6
1/4	9/32	19/32	13/16	1/2	1-1/8	4	.585	7.5
5/16	3/8	23/32	21/32	1-1/64	1-1/8	4	.730	11.8
3/8	7/16	13/16	23/32	1-1/8	1-1/2	4	.795	17
1/2	9/32	17/64	31/32	1-15/32	1-7/8	4	1.000	38.4

*After swage O.D. & numbers of presses recommended are approximate. They will vary according to dies & type of swaging tool used.

Wire Rope Assembly & Fittings

Swaged Fittings/Cable Assembly

Stainless Steel Oval Sleeves

Cable Size (in)	Oval Sleeves			Tool Selection	
	Sleeve Stock No.	Approx. Wt. (lbs) Per 1000 Sleeves	Approx. Length (in) Before Compression	Hand Tool	No. 635 Hydraulic Tool Die
1/32	168-1-VB	1/2	1/4	31-B	
3/64	168-1.5-VB4	1-1/2	3/8	51-B4-887	Oval B4
1/16	168-2-VB4	1-1/2	3/8	51-B4-887	Oval B4
3/32	168-3-VC	2-1/4	3/8	51-C-887	Oval C
1/8	168-4-VG	3-3/4	3/8	51-G-887	Oval G
5/32	168-5-VM	14	23/32	51-M-850	Oval M
3/16	168-6-VP	17	3/4	51-P-850	Oval P
7/32	168-7-VX	31	7/8		Oval X
1/4	168-8-VF2	44	1-1/8		Oval F2

Copper Button Stops

Rope Size (in)	Approx. Dimensions (in)			After Swage O.D.	Wt. Per 100
	A	B	C		
1/32	3/64	1/8	13/64	.115	.07
3/64	1/16	11/64	7/32	.155	.15
1/16	5/64	13/64	7/32	.182	.20
3/32	7/64	21/64	21/64	.261	.80
1/8	5/32	21/64	21/64	.261	.80
5/32	3/16	27/64	21/64	.350	1.3
3/16	7/32	27/64	21/64	.350	1.2
7/32	1/4	27/64	5/8	.350	2.
1/4	9/32	21/32	11/16	.600	6.

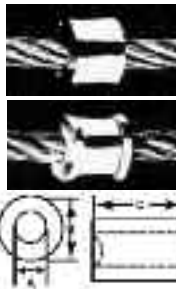

Aluminum Oval Sleeves: For Steel Cable

Size of Cable (in)	Oval Sleeves Stock No.	Hand Tools Stock No.	Approx. Wt. Per 1000 Sleeves (lbs)	Sleeve Length Before Compressed Approx. (in)	Sleeve Length After Compressed (in)
1/16	188-2-VC	51-C-887	1	3/8	7/16
3/32	188-3-VG	51-G-887	2.8	9/16	5/8
1/8	188-4-VM	51-M-850	6.1	5/8	13/16
5/32	188-5-VP	51-P-850	9	3/4	1-1/32
3/16	188-6-VX	51-X-850	15	7/8	1-3/16
1/4	188-8-VF6	3-F6-950	27	1-1/8	1-7/16
No. 635 Hydraulic Tool Dies					
5/16	188-10-VG92	VG 92	48	1-3/8	1-11/16
3/8	188-12-VJ8	Oval J8	104	1-7/8	2-3/8
7/16	188-14-VK8	Oval K8	115	1-7/8	2-3/8
1/2	188-16-VM1	Oval M1	169	2-1/8	2-3/4

Note: Mechanical hand tools and bench tools are available for compressing sleeves onto cable 1/32" to 5/16". Larger cable sizes require use of the Nicopress #635 hydraulic tool with pressing dies. Information on power press dies for high speed production will be furnished upon request.

Aluminum Oval Sleeves: For Fiber Rope

Size of Rope (in)	Oval Sleeves Stock No.	Hand Tools Stock No.	Approx. Wt. (lbs) Per 1000 Sleeves	Sleeve Length Before Compressed Approx. (in)
1/16	1700-C	51-C-887	1	3/8
1/8	1700-M	51-M-850	7	11/16
3/16	1582-P	51-P-850	9	1
1/4	1700-X	51-X-850	20	1-1/4
No. 635 Hydraulic Tool Dies				
5/16	1700-G3	1700-G3	30	1-1/8
3/8	1700-H5	1700-H5	63	1-9/16
1/2	1700-J8	1700-J8	110	2

Note: Mechanical hand tools and bench tools are available for compressing sleeves onto cable 1/32" to 5/16". Larger cable sizes require use of the Nicopress #635 hydraulic tool with pressing dies. Information on power press dies for high speed production will be furnished upon request.

Warning: Aluminum sleeves may not develop 100% holding power (swaging efficiency). Testing is recommended prior to use to determine the holding power for any particular application, especially when the possibility of personal injury or property damage exists.

CABLE ASSEMBLIES

Cable Assembly

A complete cable assembly must have the following elements:

- 1) A turnbuckle or an adjustable threaded stud to tension the cable.
- 2) An attachment point at each end, with an end fitting, that will support the tension of the cable. Unless you have these two elements, you do not have a proper cable assembly. The following cable assemblies are only a small sample of what is available. There are many different ways to make a cable assembly. Aesthetics are very important so we provide many different fittings that do the same thing but look different. You can design your rail and mix & match to come up with just the look you want.

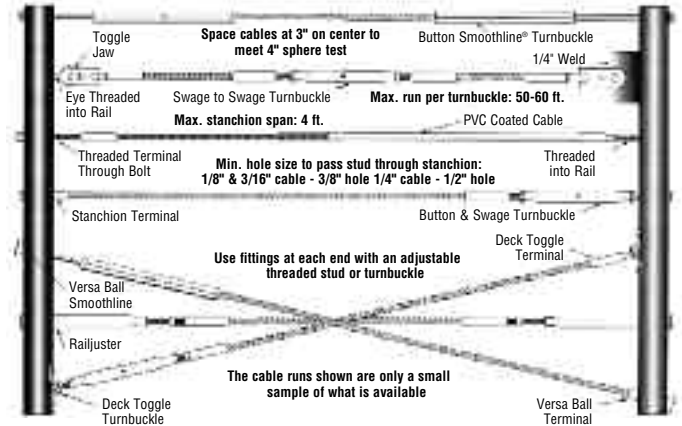

Cable Assembly: How to Measure

- Measure eye and fork terminals from center of pin holes.
- Measure ball fittings from center of ball.
- Measure stud terminals from end of terminal.
- Measure loop from bearing in loop. When ordering loops without thimbles, specify size of pin the loop is to fit around.

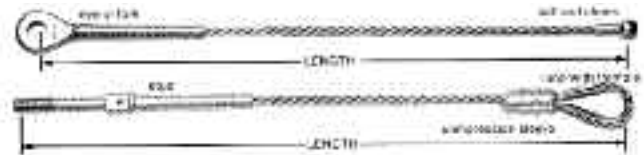

3
Wire Rope Assembly and Fittings

Wire Rope Assembly & Fittings

Cable Assembly/Swaged Cable Fittings

Fittings

Cable assemblies are available made with swaged fittings and compression sleeves. The swaged fittings develop holding power equal to the strength of the cable when properly swaged onto all metal cables. They should not be swaged onto cables having fiber cores. Our swaging is done with rotary swaging machines, which provide uniform cold-working and a smooth finish without lines or areas of overworking. All swaged fittings are proof loaded at 60% of rated cable breaking strength unless otherwise specified.

The compression oval sleeves will also develop holding power equal to the rated strength of the cable when applied to the flexible cables with the proper compression tool. We also supply the swaged fittings and the compression sleeves loose.

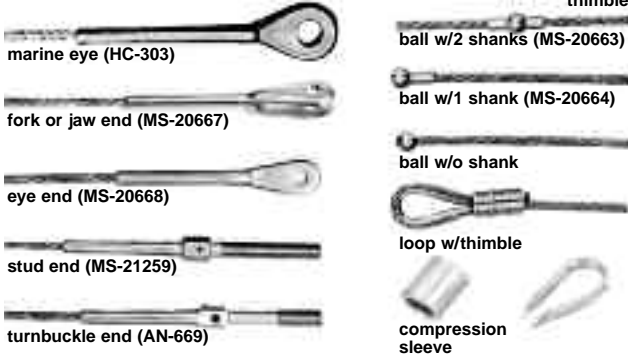
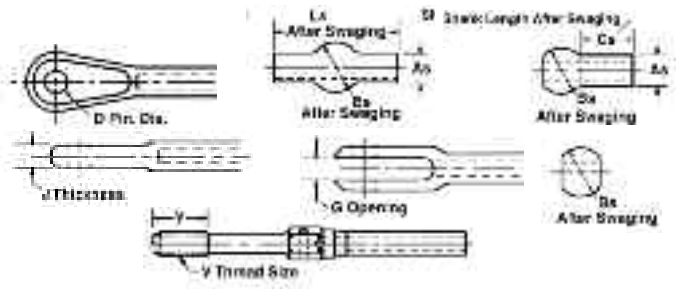

Cable Size (in)	Marine Eye J		MS-20668 Eye J		MS-20667 Fork D G		AN-669 V	MS-21259 Y	AN-669 Y	Bs	As	Cs	Ls
	.263	.218	.19	.088	.19	.093	6-40	1.045	.375	.19	.112	.156	.39
3/32	.263	.218	.19	.103	.19	.108	10-32	1.204	.5	.253	.143	.234	.578
1/8	.263	.218	.19	.19	.19	.195	1/4-28	1.376	.563	.315	.19	.313	.765
5/32	.325	.281	.25	.197	.25	.202	1/4-28	1.376	.625	.379	.222	.391	.953
3/16	.39	.359	.313	.255	.313	.26	5/16-24	1.453	.75	.442	.255	.469	1.14
7/32	.45	.406	.313	.291	.313	.296	3/8-28	1.625	.875	.505	.302	.547	1.328
1/4	.515	.468	.375	.307	.375	.313	3/8-24	1.75	.875	.567	.348	.625	1.515
9/32	.515	.468	.438	.322	.438	.327	7/16-20	1.875	1.	.632	.382	.75	1.719
5/16	.64	.593	.438	.343	.438	.348	1/2-20	2.	1.	.694	.413	.813	1.875
3/8	.64	.593	.5	.375	.5	.38	9/16-18	2.25	1.125	-	-	-	-
7/16	.765	.719	.562	.375	.562	.38	5/8-18	2.5	1.25	-	-	-	-
1/2	.89	.844	.625	.468	.625	.473	5/8-18	2.5	1.25	-	-	-	-
9/16	.89	.884	.75	.562	.75	.567	3/4-16	3.	1.5	-	-	-	-
5/8	1.015	.968	.875	.657	.875	.663	7/8-14	3.5	1.75	-	-	-	-

Fittings for larger cables are available – contact a representative for more information.

SWAGED FITTINGS

Locking Stud

MS 21260

(AN 669)† NAS650

Corrosion Resistant Steel



MS Part Nos.		Nom. Cable Dia. (Ref.)	Thread NF-3A UNF-3A	A Dia.	As Dia.	C +.006 -.000 Dia.	D	G		Dash No. (Size)	L ±.063	Ls (Ref.)	N Dia.	P	Q +.031 -.016	R +.005 -.000 Dia.	S +.062 -.000	W	Y ±.047	Lbs. Per Piece
RH Thread	LH Thread							Max.	Min.											
MS21260L2RH*	MS21260L2LH*	1/16	No. 6-40	.160	.138	.092	.188	.1139	.1094	L2*	3.491	3.67	.078	1.042	1.319	.063	.969	1.174	.375	.011
MS21260S2RH*	MS21260S2LH*	1/16	No. 6-40	.160	.138	.092	.188	.1139	.1094	S2*	2.616	2.79	.078	1.042	1.319	.063	.969	1.174	.375	.01
MS21260L3RH*	MS21260L3LH*	3/32	No. 10-32	.218	.190	.133	.250	.1638	.1568	L3*	3.738	3.86	.109	1.261	1.581	.063	1.188	1.411	.500	.024
MS21260S3RH*	MS21260S3LH*	3/32	No. 10-32	.218	.190	.133	.250	.1638	.1568	S3*	2.863	2.98	.109	1.261	1.581	.063	1.188	1.411	.500	.020
MS21260L4RH*	MS21260L4LH*	1/8	1/4-28	.250	.219	.195	.313	.2224	.2152	L4*	4.020	4.28	.141	1.511	1.863	.098	1.438	1.682	.563	.040
MS21260S4RH*	MS21260S4LH*	1/8	1/4-28	.250	.219	.195	.313	.2224	.2152	S4*	3.145	3.40	.141	1.511	1.863	.098	1.438	1.682	.563	.0236
MS21260L5RH*	MS21260L5LH*	5/32	1/4-28	.297	.250	.195	.313	.2224	.2152	L5*	4.314	4.66	.172	1.761	2.157	.098	1.688	1.958	.625	.05
MS21260S5RH*	MS21260S5LH*	5/32	1/4-28	.297	.250	.195	.313	.2224	.2152	S5*	3.439	3.78	.172	1.761	2.157	.098	1.688	1.958	.625	.044
MS21260L6RH*	MS21260L6LH*	3/16	5/16-24	.359	.313	.245	.375	.2830	.2754	L6*	4.612	4.78	.203	2.011	2.455	.098	1.938	2.237	.750	.086
MS21260S6RH*	MS21260S6LH*	3/16	5/16-24	.359	.313	.245	.375	.2830	.2754	S6*	3.737	3.90	.203	2.011	2.455	.098	1.938	2.237	.750	.070
MS21260-7RH*	MS21260-7LH*	7/32	3/8-24	.427	.375	.306	.438	.3454	.3378	-7*	4.914	5.21	.234	2.261	2.757	.098	2.188	2.518	.875	.130
MS21260-8RH*	MS21260-8LH*	1/4	3/8-24	.494	.438	.306	.500	.3454	.3378	-8*	5.218	5.52	.265	2.511	3.061	.098	2.438	2.784	.875	.170
MS21260-9RH*	MS21260-9LH*	9/32	7/16-20	.563	.500	.361	.625	.4052	.3972	-9*	5.542	5.90	.297	2.761	3.385	.098	2.688	3.076	1.000	.22
MS21260-10RH*	MS21260-10LH*	5/8	1/2-20	.635	.563	.406	.688	.4678	.4597	-10*	5.875	6.30	.328	3.011	3.718	.098	2.938	3.326	1.000	.35
MS21260-12RH*	MS21260-12LH*	3/8	9/16-18	.703	.625	.476	.750	.5285	.5201	-12*	6.608	7.01	.390	3.511	4.281	.098	3.438	3.828	1.125	.50
MS21260-14RH	MS21260-14LH	7/16	5/8-18	.781	.688	.538	.812	.5909	.5826	-14	7.468	7.94	.468	4.011	4.812	.098	3.938	4.375	1.250	.75
MS21260-16RH	MS21260-16LH	1/2	5/8-18	.844	.750	.538	.875	.5909	.5826	-16	8.718	9.28	.531	4.698	5.562	.125	4.625	5.093	1.250	1.00

NOTE: Larger sizes and specs available upon request. * Denotes stock item.

† AN 669 same as MS 21260 but w/o slotted end

Stud MS 21259

(AN 666)

Corrosion Resistant Steel



MS Part Nos.		Nom. Cable Dia. Ref.	Thread B UN-3A UNF-3A	A Dia.	As Dia.	C Dia.	D	L +.015 -.000	Ls Ref.	N Dia.	P	R +.005 -.000 Dia.	S +.062 -.000	W ±.016	Y +.063 -.000	Lbs. Per Piece
RH Thread	LH Thread															
MS21259-2RH*	MS21259-2LH*	1/16	No. 6-40	.160	.138	.121	.188	2.473	2.65	.078	1.042	.063	.969	1.174	1.045	.01
MS21259-3RH*	MS21259-3LH*	3/32	No. 10-32	.218	.190	.169	.250	2.879	3.00	.109	1.261	.063	1.188	1.411	1.204	.0225
MS21259-4RH*	MS21259-4LH*	1/8	1/4-28	.250	.219	.226	.313	3.333	3.59	.141	1.511	.063	1.438	1.682	1.376	.0375
MS20259-5RH*	MS21259-5LH*	5/32	1/4-28	.297	.250	.226	.313	3.627	3.97	.172	1.761	.063	1.688	1.958	1.376	.0475
MS21259-6RH*	MS21259-6LH*	3/16	5/16-24	.359	.313	.285	.375	4.002	4.17	.203	2.011	.098	1.938	2.237	1.458	.08
MS21259-7RH*	MS21259-7LH*	7/32	3/8-24	.427	.375	.347	.438	4.516	4.81	.234	2.261	.098	2.188	2.518	1.625	.12
MS21259-8RH*	MS21259-8LH*	1/4	3/8-24	.494	.438	.347	.500	4.937	5.24	.265	2.511	.098	2.438	2.784	1.750	.165
MS21259-9RH*	MS21259-9LH*	9/32	7/16-20	.563	.500	.405	.625	5.391	5.75	.297	2.761	.098	2.688	3.076	1.875	.265
MS21259-10RH*	MS21259-10LH*	5/16	1/2-20	.635	.563	.467	.688	5.844	6.27	.323	3.011	.098	2.938	3.026	2.000	.375
MS21259-12RH*	MS21259-12LH*	3/8	9/16-18	.703	.625	.529	.750	6.656	7.06	.390	3.511	.098	3.438	3.828	2.250	.500
MS21259-14RH	MS21259-14LH	7/16	5/8-18	.781	.688	.592	.812	7.437	7.91	.468	4.011	.098	3.938	4.375	2.300	.625
MS21259-16RH	MS21259-16LH	1/2	5/8-18	.844	.750	.592	.875	8.187	8.75	.531	4.698	.125	4.625	5.093	2.500	.75

Be sure to specify RH or LH Thread NOTE: Larger sizes and specs available

Wire Rope Assembly & Fittings

Swaged Cable Fittings

Eye End MS 20668



MS Part No.	Nom. Cable Dia. Ref.	A Dia.	As Dia.	C ±.020	D Dia.	J	L +.020 -.000	Ls Ref.	N Dia.	P	U +.025 -.010 Dia.	Y	Z Min.	Lbs. Per Piece	
MS20668-2*	1/16	.160	.138	+.000 -.005	.523	.190	.088	1.631	1.809	.078	1.042	.359	.072	.662	.009
MS20668-3*	3/32	.218	.190	"	.707	.190	.103	2.043	2.160	.109	1.261	.438	.092	.856	.018
MS20668-4*	1/8	.250	.219	"	.738	.190	.190	2.337	2.593	.141	1.511	.500	.103	.900	.035
MS20668-5*	5/32	.297	.250	"	.831	.250	.197	2.684	3.029	.172	1.761	.640	.131	.997	.050
MS20668-6*	3/16	.359	.313	"	.903	.313	.255	3.019	3.187	.203	2.061	.781	.155	1.082	.090
MS20668-7*	7/32	.427	.375	+.000 -.007	1.007	.313	.291	3.382	3.678	.234	2.261	.813	.187	1.195	.135
MS20668-8*	1/4	.494	.438	"	1.133	.375	.307	3.763	4.062	.265	2.511	.968	.221	1.326	.200
MS20668-9*	9/32	.563	.500	+.000 -.008	1.257	.438	.322	4.153	4.512	.297	2.761	1.109	.251	1.465	.250
MS20668-10*	5/16	.635	.563	"	1.373	.438	.343	4.546	4.969	.328	3.011	1.218	.281	1.609	.400
MS20668-12*	3/8	.703	.625	"	1.688	.500	.375	5.562	5.968	.390	3.511	1.500	.320	2.124	.575
MS20668-14	7/16	.781	.688	"	1.968	.562	.375	6.398	6.867	.468	4.011	1.750	.350	2.460	.790
MS20668-16	1/2	.844	.750	+.000 -.009	2.115	.625	.468	7.323	7.886	.531	4.698	1.875	.406	2.698	1.050

* Denotes Stock Item . Larger sizes & specs available upon request.

Marine Eye EY1

Corrosion Resistant Steel

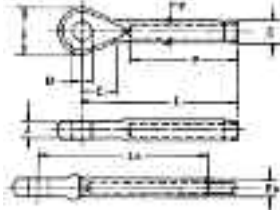

*Denotes Stock Item

Part No.	Cable Size	C +.46 -.065	D +.010 -.010	E +.000 -.005	F +.006 -.000	J +1/32	L	P	U +.041 -.078	After Swage Es +.000 -.009	After Swage Ls Ref.	Lbs. Per Piece
EY1-2*	1/16	.500	.264	.160	.078	.218	1.500	1.063	.594	.138	1.809	.015
EY1-3*	3/32	.500	.264	.218	.109	.218	1.758	1.188	.594	.190	2.070	.028
EY1-4*	1/8	.500	.264	.250	.141	.218	2.088	1.500	.594	.219	2.401	.033
EY1-5*	5/32	.580	.327	.297	.172	.281	2.355	1.688	.750	.250	2.709	.055
EY1-6*	3/16	.710	.389	.359	.201	.359	2.750	2.000	.875	.313	3.147	.090
EY1-7*	7/32	.800	.452	.427	.228	.406	3.220	2.313	1.000	.375	3.787	.150
EY1-8*	1/4	.900	.514	.494	.265	.468	3.625	2.500	1.125	.438	4.282	.250
EY1-9*	9/32	.990	.514	.563	.295	.468	3.795	2.688	1.125	.500	4.514	.330
EY1-10*	5/16	1.080	.640	.635	.325	.593	4.495	3.250	1.375	.563	5.274	.500
EY1-12*	3/8	1.150	.640	.703	.390	.593	4.930	3.500	1.375	.625	5.659	.670
EY1-14	7/16	1.240	.765	.781	.468	.719	6.375	4.125	1.625	.688	6.750	1.00
EY1-16	1/2	1.290	.890	.844	.531	.844	7.375	4.750	1.875	.750	7.187	1.25

Strap Forks - Strap, Fork End Mil Spec. NAS 1435-K

Corrosion Resistant Steel

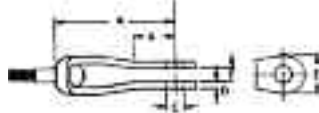

Part Number	NAS No.	Rope Dia.	A	B	C	D	E	F	Lbs. Per Piece
SP 2-2*	NAS 1435K-2	1/16	1-1/16	.454	.188	.042	3/8	.093	.006
SP 2-3*	NAS 1435K-3	3/32	1-1/2	.616	.188	.049	7/16	.108	.013
SP 2-4*	NAS 1435K-4	1/8	1-5/8	.638	.188	.093	1/2	.195	.030
SP 2-5	NAS 1435K-5	5/32	1-31/32	.699	.250	.096	9/16	.202	.042
SP 2-6	NAS 1435K-6	3/16	2-3/16	.750	.313	.125	11/16	.260	.083

* Denotes Stock Item.

Strap Eyes - Strap, Eye End Mil Spec. NAS 1435-E Corrosion Resistant Steel

Corrosion Resistant Steel

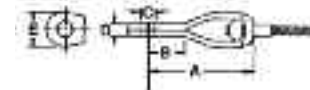

Part Number	NAS No.	Rope Dia.	A	B	C	D	E	Lbs. Per Piece
SP 1-2*	NAS 1435E-2	1/16	1-1/16	.454	.188	.088	3/8	.006
SP 1-3*	NAS 1435E-3	3/32	1-1/2	.616	.188	.103	7/16	.013
SP 1-4*	NAS 1435E-4	1/8	1-5/8	.638	.188	.190	1/2	.030
SP 1-5	NAS 1435E-5	5/32	1-15/16	.699	.250	.197	9/16	.042
SP 1-6	NAS 1435E-6	3/16	2-3/16	.750	.313	.255	11/16	.083

* Denotes Stock Item.

Stanchion Terminal

- Machine Swage & Hand Crimp

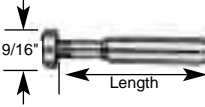

Cat. No	Wire Size (in)	Length (in)
100-110-1	1/8	2
25-306-5F	3/16	2-1/8
25-308-7-5F	1/4	2-1/2
* Hand Crimp		
26-405-5F	1/8	3-3/16
27-405-5F	3/16	3-13/16

Versa Ball Terminal

- Machine Swage & Hand Crimp

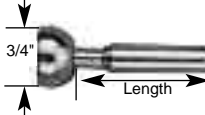

Requires 11/32" Dia. Hole in Stanchion

Cat. No	Wire Size (in)	Length (in)
25-304-5V	1/8	1-11/16
25-306-5V	3/16	2-1/8
25-308-7-5V	1/4	2-1/2
* Hand Crimp		
26-405-5V	1/8	2-3/8
27-405-5V	3/16	2-3/4

Threaded Terminal

- Machine Swage & Hand Crimp

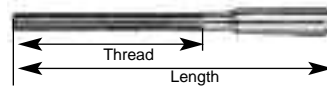

Cat. No	Thread (in)	Wire Size (in)	Length (in)
30-603-1	1/4-28 x 2-1/2	1/8	4-1/4
30-608-1	1/4-28 x 2-1/2	3/16	4-1/4
30-615-1	5/16-24 x 2-1/2	1/4	4-3/4
30-613-1	3/8-24 x 3"	1/4	5-1/4
* Hand Crimp			
31-603-1	1/4-28 x 2-1/2	1/8	4-13/16
31-607-1	1/4-28 x 2-1/2	3/16	4-13/16

Cotter Pin

Corrosion Resistant Steel

Part No.	A	B	C
PI 5-1*	.062	.75	1/8
PI 5-2*	.093	1.00	3/16

*Denotes Stock Item



Clevis Pins PI1

Corrosion Resistant Steel

Part No.	Fits MS Nos. Indicated	Cable Dia.	A	B	C	D	E	L	F	Lbs Per Piece
PI-1-3*	MS20667-2	1/16	3/16	5/16	1/16	3/64	.081	7/16	5/16	.004
	MS20667-3	3/32	3/16	5/16	1/16	3/64	.081	7/16	5/16	.004
PI 1-4*	MS20667-4	1/8	3/16	5/16	1/16	3/64	.081	17/32	13/32	.005
PI 1-5*	MS20667-5	5/32	1/4	3/8	1/16	3/64	.098	17/32	13/32	.009
PI 1-6*	MS20667-6	3/16	5/16	7/16	1/16	3/64	.098	23/32	9/16	.017
PI 1-7*	MS20667-7	7/32	5/16	7/16	1/16	1/16	.098	27/32	11/16	.020
PI 1-8*	MS20667-8	1/4	3/8	1/2	3/32	1/16	.098	31/32	13/16	.033
PI 1-9	MS20667-9	9/32	7/16	5/8	3/32	1/16	.1405	1-3/32	7/8	.040
PI 1-10*	MS20667-10	5/16	7/16	5/8	3/32	1/16	.1405	1-3/32	7/8	.040
PI 1-12*	MS20667-12	3/8	1/2	11/16	1/8	5/64	.1405	1-7/32	1	.050

*Denotes Stock Item

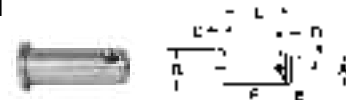

Wire Rope Assembly & Fittings

Swaged Cable Fittings

Fork End MS

20667
Corrosion Resistant Steel

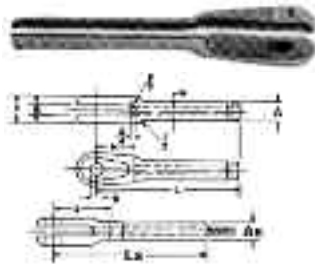

Plain Ball BA3

Corrosion Resistant Steel



Part No.	Cable Dia. (in)	Dimensions (in)						Min. Breaking Strength (lbs)	Wt. Per Piece (lbs)
		A	B	C	D	E	Sphere Dia. F		
BA3-1*	1/32	.211	.035	.141	.026	.083	.1905	60	.002
		.208	.038	.137	.016	.073	.1875		
BA3-1.5*	3/64	.211	.053	.141	.026	.083	.1905	215	.0019
		.208	.057	.137	.016	.087	.1875		
BA3-2*	1/16	.211	.076	.141	.026	.083	.1905	385	.0017
		.208	.073	.137	.016	.073	.1875		
BA3-3*	3/32	.288	.106	.174	.041	.099	.253	735	.004
		.284	.102	.170	.031	.089	.250		
BA3-4*	1/8	.355	.143	.190	.041	.142	.317	1,200	.006
		.351	.139	.184	.031	.132	.312		
BA3-5*	5/32	.429	.175	.227	.041	.170	.380	1,680	.009
		.425	.171	.222	.031	.160	.375		
BA3-6*	3/16	.498	.207	.264	.041	.197	.442	2,520	.01
		.493	.203	.259	.031	.187	.437		

*Denotes Stock Item NOTE: BA3 same as Boeing BAC T14B and NAS 494

Wire Rope Assembly and Fittings

MS Part Number	Nom. Cable Dia. Ref.	A Dia.	As Dia.	D Dia.	F +.010 - .005	G ±.003	H	L +.020 - .000	Ls Ref.	N Dia.	Z Min.	Lbs. Per Piece
MS20667-2*	1/16	.160	.138	.190	.218	.093	.500	1.572	1.75	.078	.600	.01
MS20667-3*	3/32	.218	.190	.190	.254	.108	.670	1.945	2.06	.109	.757	.02
MS20667-4*	1/8	.250	.219	.190	.383	.195	.735	2.352	2.61	.141	.914	.0325
MS20667-5*	5/32	.297	.250	.250	.406	.202	.800	2.655	3.00	.172	.967	.05
MS20667-6*	3/16	.359	.313	.313	.543	.260	.880	3.071	3.24	.203	1.133	.09
MS20667-7*	7/32	.427	.375	.313	.625	.296	.970	3.440	3.74	.234	1.252	.15
MS20667-8*	1/4	.494	.438	.375	.688	.313	1.070	3.806	4.10	.265	1.368	.20
MS20667-9*	9/32	.563	.500	.438	.719	.327	1.170	4.120	4.48	.297	1.432	.30
MS20667-10*	5/16	.635	.563	.438	.765	.348	1.268	4.438	4.86	.328	1.500	.3812
MS20667-12*	3/8	.703	.625	.500	.830	.380	1.525	5.333	5.74	.390	1.895	.575
MS20667-14*	7/16	.781	.688	.562	.830	.380	1.776	6.402	6.57	.468	2.164	.775
MS20667-16	1/2	.844	.750	.625	1.035	.473	1.903	6.938	7.50	.531	2.313	1.625

Larger sizes & specs available upon request.

* Denotes Stock Item.

Stamped Eyes SW-730 & 731

Tuf-Grip Stamped Eyes are convenient, economical fittings designed for several applications such as door restraints, telephone book binders, vehicle glove compartment restraints and many others.

Their one-piece, drop-forged construction helps assure long-lasting use. Measure their length from the end of the fitting to the bearing of the eye.

For zinc-plated construction, choose the SW-730 Stamped Eye. For stainless steel, choose the SW-731.



SW-730				Dimensions (in)				SW-731				Dimensions (in)			
Dash No.	To Fit Cable dia.	Pin Hole D	Thickness E	Dash No.	To Fit Cable dia.	Pin Hole D	Thickness E	Dash No.	To Fit Cable dia.	Pin Hole D	Thickness E	Dash No.	To Fit Cable dia.	Pin Hole D	Thickness E
151	3/64	0.160	0.060	151	3/64	0.160	0.060	205	1/16	0.260	0.060	401	1/8	0.250	0.125
152	3/64	0.190	0.060	152	3/64	0.190	0.060	206	1/16	0.204	0.060	402	1/8	0.316	0.125
201	1/16	0.129	0.035	201	1/16	0.129	0.035	301	3/32	0.205	0.093	403	1/8	0.375	0.125
202	1/16	0.194	0.035	202	1/16	0.194	0.035	302	3/32	0.250	0.093	404	1/8	0.500	0.125
203	1/16	0.129	0.060	203	1/16	0.129	0.060	303	3/32	0.375	0.093				
204	1/16	0.190	0.060	204	1/16	0.190	0.060	304	3/32	0.500	0.093				
205	1/16	0.260	0.060	205	1/16	0.260	0.060								
206	1/16	0.204	0.060	206	1/16	0.204	0.060								
301	3/32	0.205	0.093	301	3/32	0.205	0.093								
302	3/32	0.250	0.093	302	3/32	0.250	0.093								
303	3/32	0.375	0.093	303	3/32	0.375	0.093								
304	3/32	0.500	0.093	304	3/32	0.500	0.093								

Terminal, Cylindrical ST 24

Also known as "Stop Buttons", "Sleeves," "Boeing Buttons," (Boeing Part No. BACT 14A), these Stainless Steel Terminals have a multitude of uses. When properly applied they will hold the breaking strength of the wire rope (except for 1 x 7 or 1 x 19 constructions).

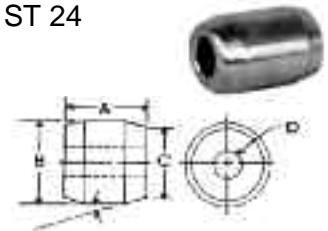

Part No.	Cable Dia.	A	B	C	D	C=As	Die Size	Lbs. Per Piece
ST24-2*	1/16	.224	.221	.190	.076	.190	3/32	.0019
		.214	.217	.185	.073			
ST24-3*	3/32	.333	.252	.219	.107	.219	1/8	.005
		.323	.248	.214	.104			
ST24-4*	1/8	.416	.298	.250	.146	.250	5/32	.0075
		.406	.294	.245	.141			
ST24-5*	5/32	.510	.377	.313	.177	.313	3/16	.01
		.500	.373	.303	.172			
ST24-6*	3/16	.635	.439	.315	.208	.375	7/32	.114
		.625	.435	.370	.203			

Minimum breaking strength of ST24 Terminals equals minimum breaking strength of flexible carbon steel wire rope conforming to Specification MIL-W-83420, For swaging of these terminals, the dies for the next larger size AN/MS Standard Terminals are required.

Double Shank Ball MS 20663

Corrosion Resistant Steel

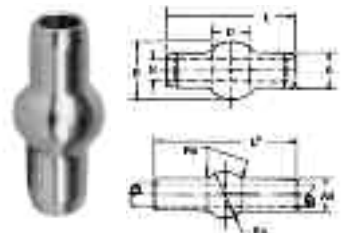

MS Part No.	Nom. Cable Dia.	Dimensions (in)										Wt. Per Piece (lbs)
		A Dia.	As Dia.	B Dia.	Bs Spherical Dia.	D	L ±.0075	Ls Ref.	N Dia.	Rs Max. Rad.		
MS20663C2*	1/16	.127	.112	.207	.114	.362	.390	.073	.014	.0016		
MS20663C3*	3/32	.163	.143	.277	.153	.525	.578	.104	.019	.0032		
MS20663C4*	1/8	.218	.190	.345	.215	.895	.968	.139	.023	.0094		
MS20663C5*	5/32	.254	.222	.419	.227	.850	.953	.169	.028	.0125		
MS20663C6*	3/16	.293	.255	.487	.264	1.012	1.140	.201	.033	.025		
MS20663C7*	7/32	.347	.302	.555	.3025	1.175	1.328	.233	.038	.032		
MS20663C8*	1/4	.401	.348	.624	.357	1.337	1.515	.264	.042	.040		
MS20663C9	9/32	.439	.382	.694	.392	1.497	1.719	.297	.046	.042		
MS20663C10*	5/16	.475	.413	.763	.415	1.664	1.875	.328	.046	.043		

*Denotes Stock Item

Wire Rope Assembly & Fittings

Swaged Cable Fittings/Swaged Turnbuckle Fittings

Single Shank Ball MS

20664
Corrosion Resistant Steel



MS Part Number	Nom. Cable Dia.	Dimensions (in)										Wt. Per Piece (lbs)
		A Dia.	As Dia.	B Dia.	Bs Spherical Dia.	Cs	D	E Rad Ref	L	N Dia.	Rs Max Rad	
MS20664C2*	1/16	.132	.112	.212	.190	.156	.114	.0825	.2685	.073	.014	.0019
MS20664C3*	3/32	.168	.143	.282	.253	.234	.152	.110	.384	.104	.019	.005
MS20664C4*	1/8	.223	.190	.350	.315	.313	.1895	.137	.500	.139	.023	.0075
MS20664C5*	5/32	.259	.222	.424	.379	.391	.2275	.165	.616	.169	.028	.01
MS20664C6*	3/16	.298	.255	.492	.442	.469	.2645	.192	.730	.201	.033	.015
MS20664C7*	7/32	.352	.302	.560	.505	.547	.3025	.220	.846	.233	.038	.025
MS20664C8*	1/4	.406	.348	.629	.567	.625	.3395	.247	.962	.264	.042	.03
MS20664C9	9/32	.444	.382	.699	.632	.750	.3775	.275	1.078	.297	.046	.05
MS20664C10*	5/16	.480	.413	.768	.694	.813	.4145	.302	1.193	.328	.046	.066

*Denotes Stock Item

Jaw Smooth Turnbuckle

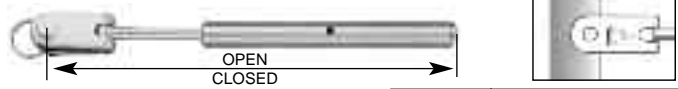

The Smooth Line Turnbuckles are state-of-the-art fittings. The cable is terminated internally so one does not see a swage terminal (or threads) as on a conventional turnbuckle. The Jaw Smooth Line Turnbuckle adapts itself to wide variety of projects. The jaw will easily attach to eyes, tabs or in a channel.

Cat. No.	Wire Size (in)	Open (in)	Closed (in)
60-700	1/8	8	6-5/16
60-702	3/16	8	6-5/16
* Hand Crimp			
26-715	1/8	8	6-5/16
27-715	3/16	8	6-5/16

Deck Toggle Smooth Line Turnbuckle



The Deck Toggle Smooth Line Turnbuckle will mount to any flat surface. It can be through bolted by its two tabs and also has the ability to toggle 140°.

Cat. No.	Wire Size (in)	Open (in)	Closed (in)
60-700-1	1/8	8	6-5/16
60-702-1	3/16	8	6-5/16
* Hand Crimp			
26-715-1	1/8	8	6-5/16
27-715-1	3/16	8	6-5/16

SWAGED TURNBUCKLE FITTINGS

Button & Swage Turnbuckle



The Button and Swage Turnbuckle has a clean simple look with no jaw. It must be used on a straight run and attached in a through hole with the button on the backside of the baluster.

Cat. No.	Wire Size (in)	Open (in)	Closed (in)
19-314-10F	1/8	11-1/2	8-1/4
19-316-10F	3/16	11-1/2	8-1/4
19-308-7F	1/4	11-3/4	8
* Hand Crimp			
26-412-10F	1/8	11-11/16	8-1/8
27-412-10F	3/16	12	8-1/2

Versa Ball & Swage Turnbuckle



The Versa Ball and Swage Turnbuckle is made to accept the angles of stairways. The versa-ball allows the turnbuckle to integrate itself to your desired angle. The ball allows this turnbuckle to gimbal in its mount.

Note: 5/32" cable size available.

Cat. No.	Wire Size (in)	Open (in)	Closed (in)
19-314-10V	1/8	11-1/4	8-1/4
19-316-10V	3/16	11-1/4	8-1/4
19-308-7V	1/4	11-1/2	7-3/4
* Hand Crimp			
26-412-10V	1/8	11-11/16	8-1/8
27-412-10V	3/16	12	8-1/2

Swage to Swage Turnbuckle

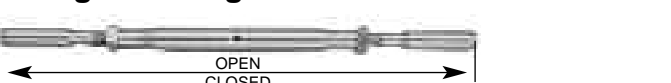

Appearing in the middle of the cable, the Swage to Swage Turnbuckle needs a fitting at each end to make a complete assembly. You need to use three fittings per cable run but it makes for a distinctive look.

Also available in new "shortie" sizes, 3" long body with 2" of adjustment.

Cat. No.	Wire Size (in)	Open (in)	Closed (in)
19-314-3	1/8	11-3/4	8-3/4
19-316-6	3/16	11-3/4	8-3/4
19-308-27	1/4	13-1/4	9-3/4
19-308-2	1/4	14-7/8	10-5/8
* Hand Crimp			
26-412-3	1/8	12-1/2	9-1/2
27-412-6	3/16	12-1/2	9-1/2

Button Smooth Line Turnbuckle

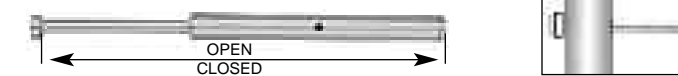

The Button Smooth Line Turnbuckle has the cleanest, simplest look of all the Smooth Lines. The button retains the fitting in a through hole in the baluster. The fitting is used in straight line runs.

Cat. No.	Wire Size (in)	Open (in)	Closed (in)
60-710-LF	1/8	9-9/16	7-13/16
60-712-LF	3/16	9-9/16	7-13/16
* Hand Crimp			
26-725-LF	1/8	9-9/16	7-13/16
27-725-LF	3/16	9-9/16	7-13/16

Versa Ball Smooth Line Turnbuckle



The Versa Ball Smooth Line Turnbuckle gimbal in its own mount, making it the turnbuckle of choice on stairways or anywhere a cable installation at a divergent angle is needed.

Cat. No.	Wire Size (in)	Open (in)	Closed (in)
60-710-LV	1/8	9-9/16	7-13/16
60-712-LV	3/16	9-9/16	7-13/16
* Hand Crimp			
26-725-LV	1/8	9-9/16	7-13/16
27-725-LV	3/16	9-9/16	7-13/16

Railjuster Turnbuckle

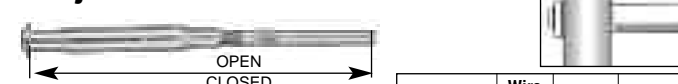

The Railjuster Turnbuckle is made for quick assembly with an allen wrench and an adjustable wrench once it is swaged to the wire.

*Not a true 1/8" fitting (sleeve)

Cat. No.	Wire Size (in)	Open (in)	Closed (in)
70-314*	1/8	6-1/2	5
70-316	3/16	6-1/2	5
* Hand Crimp			
26-714*	1/8	7-1/4	5-3/4
27-716	3/16	7-1/4	5-3/4

3
Wire Rope
Assembly
and Fittings

Wire Rope Assembly & Fittings

Swaged Turnbuckle Fittings/End Fittings

19 Series "Shortie" Turnbuckle

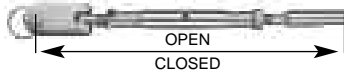

All 1/4-28 body turnbuckles are available in a new shorter length. Body length is 3" for 2" of total adjustment. Add "S" to std. cat. no., same price.

Acorn Nuts

The capped acorn nut secures terminal ends leaving no exposed threads or rough edges.

Cat No. Size
35-600 1/4-28



*Versa Ball, Buttons, Washers and Nuts sold separately.

Machined Series: Closed Body Double Socket Turnbuckle

Rope Size (in)	Self-Colored Steel	Zinc Plated Steel	Stainless Steel	Bronze	Dimensions (in)		Take-up (in)
					C Min.	D	
1/16	ID-5506-N	ID-5506-V	IS-5506	IZ-5506	6-3/8	7/16	2-1/2
3/32	ID-5509-N	ID-5509-V	IS-5509	IZ-5509	7-1/4	9/16	2-7/8
1/8	ID-5512-N	ID-5512-V	IS-5512	IZ-5512	7-1/4	9/16	2-7/8
5/32	ID5515-N	ID-5515-V	IS-5515	IZ-5515	8-5/8	11/16	3-1/8
3/16	ID-5518-N	ID-5518-V	IS-5518	IZ-5518	8-5/8	11/16	3-1/8
7/32	ID-5521-N	ID-5521-V	IS-5521	IZ-5521	11-7/8	7/8	4-13/16
1/4	ID-5525-N	ID-5525-V	IS-5525	IZ-5525	11-7/8	7/8	4-13/16
9/32	ID-5528-N	ID-5528-V	IS-5528	IZ-5528	12-7/8	1	4-9/16
5/16	ID-5531-N	ID-5531-V	IS-5531	IZ-5531	12-7/8	1	4-9/16
3/8	ID-5537-N	ID-5537-V	IS-5537	IZ-5537	14-1/2	1-1/8	5-5/16
7/16	ID-5543-N	ID-5543-V	IS-5543	IZ-5543	18-5/8	1-5/16	8-1/16
1/2	ID-5550-N	ID-5550-V	IS-5550	IZ-5550	19-1/4	1-1/2	8-1/16

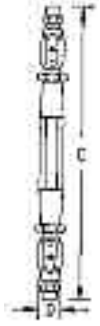

NOTE: A swaged turnbuckle body may be substituted for smaller rope sizes, resulting in slightly longer overall length.

3 Wire Rope Assembly and Fittings

Deck Toggle & Swage Turnbuckle

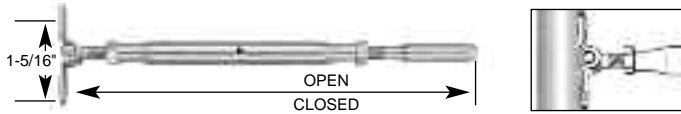

Our DeckToggle and Swage Turnbuckle can be mounted to any flat surface and is held in place by two tabs suitable for through bolting. The best feature of the deck toggle is it can articulate 140°.

Also available in new "Shortie" size, 3" long body with 2" of adjustment.

Cat. No.	Wire Size (in)	Open (in)	Closed (in)
19-314-1T	1/8	10-3/4	7-3/4
19-316-1T	3/16	11-1/4	8-1/4
* Hand Crimp			
26-412-1T	1/8	11-1/2	8-1/2
27-412-1T	3/16	11-1/2	8-1/2

END FITTINGS:

Toggle Jaw

- Machine Swage & Hand Crimp

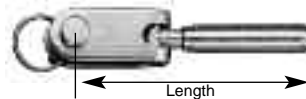

*Not a true 1/8" fitting (sleeve)

Cat. No	Wire Size (in)	Length (in)
25-314*	1/8	3-3/16
25-316	3/16	3-5/16
25-308-7	1/4	3-1/4
25-308	1/4	3-3/4
*Hand Crimp		
26-415*	1/8	3-3/16
27-415	3/16	3-13/16

Classic Jaw & Swage Turnbuckle

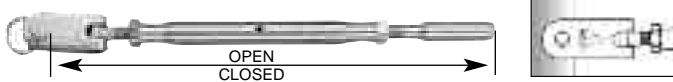

The Classic Jaw and Swage Turnbuckle is an excellent choice for a wide variety of applications. A clevis pin in the jaw attaches to the eyes, tabs or in a channel.

Also available in new "Shortie" size, 3" long body with 2" of adjustment.

Cat. No.	Wire Size (in)	Open (in)	Closed (in)
19-314	1/8	11-1/4	8-1/4
19-316	3/16	11-1/4	8-1/4
19-308-7	1/4	12-3/4	9
19-308	1/4	14-1/4	10
* Hand Crimp			
26-412	1/8	11-5/8	8-3/4
27-412	3/16	11-5/8	8-3/4

Deck Terminal - Machine Swage & Hand Crimp

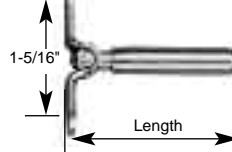

Cat. No	Wire Size (in)	Length (in)
25-304-1	1/8	2-1/8
25-316-1T	3/16	2-1/8
* Hand Crimp		
26-405-1	1/8	2-3/4
27-415-1T	3/16	3

Machined Series: Closed Body Double Clevis & Socket Turnbuckle

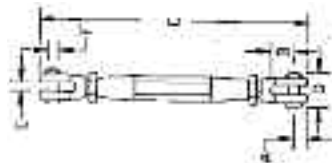

Rope Size	Catalog Numbers				Dimensions (in)							Takeup (in)
	Self-Colored Steel	Zinc Plated Steel	Stainless Steel	Bronze	A	B	C Min.	D	E	F		
1/16	IJD-406-N	IJD-406-V	IJS-406	IJZ-406	17/64	3/8	5-5/32	21/32	3/16	3/16	2-1/2	
3/32	IJD-409-N	IJD-409-V	IJS-409	IJZ-409	5/16	1/2	6-1/4	13/16	1/4	1/4	2-7/8	
1/8	IJD-412-N	IJD-412-V	IJS-412	IJZ-412	5/16	1/2	6-1/4	13/16	1/4	1/4	2-7/8	
5/32	IJD-415-N	IJD-415-V	IJS-415	IJZ-415	3/8	5/8	7-5/16	15/16	5/16	5/16	3-1/8	
3/16	IJD-418-N	IJD-418-V	IJS-418	IJZ-418	3/8	5/8	7-5/16	15/16	5/16	5/16	3-1/8	
7/32	IJD-421-N	IJD-421-V	IJS-421	IJZ-421	15/32	3/4	10	1-1/8	3/8	3/8	4-13/16	
1/4	IJD-425-N	IJD-425-V	IJS-425	IJZ-425	15/32	3/4	10	1-1/8	3/8	3/8	4-13/16	
9/32	IJD-428-N	IJD-428-V	IJS-428	IJZ-428	17/32	7/8	10-1/2	1-5/16	3/8	7/16	4-9/16	
5/16	IJD-431-N	IJD-431-V	IJS-431	IJZ-431	17/32	7/8	10-1/2	1-5/16	3/8	7/16	4-9/16	
3/8	IJD-437-N	IJD-437-V	IJS-437	IJZ-437	5/8	1	12	1-7/16	1/2	1/2	5-5/16	
7/16	IJD-443-N	IJD-443-V	IJS-443	IJZ-443	23/32	1-1/4	15-13/16	1-5/8	7/16	5/8	8-1/16	
1/2	IJD-450-N	IJD-450-V	IJS-450	IJZ-450	51/64	1-3/8	16-7/32	1-7/8	1/2	11/16	8-1/16	

NOTE: A swaged turnbuckle body may be substituted for smaller rope sizes, resulting in an overall length slightly longer than indicated.