

SECTION 30
Equipment

AIR TIMER CONTROL	30-11	Electric	30-14	PAVERS	
ARC		Kerosene	30-19-20	Saw	30-4
Welder	30-6-7	Natural Gas	30-16-20	PEDESTAL	
BLOCK SAW	30-4	Propane	30-16-20	Fans	30-13
BLOWER		HOSE		PLASMA CUTTER	30-7
Air	30-13	Pressure Washer	30-9	PNEUMATIC SAW	
BOLT		HYDRAULIC		Concrete Cutting Saw	30-4
Tension Calibrator	30-11	Concrete Saw	30-4-5	PRESSURE WASHER	
BRUSH		Load Reliever	30-11	Brush	30-9
Pressure Washer	30-9	INCANDESCENT LAMPS	30-15	Coldwater	30-8
CALIBRATOR		INFRARED HEATERS	30-14-20	Hose	30-9
Bolt Tension	30-11	INJECTOR		Hot water	30-9
Torque Wrench	30-11	Detergent	30-9	Injector, Detergent	30-9
CEILING		Sand	30-9	Injector, Sand	30-9
Fans	30-14	IRONWORKER MACHINES	30-11-12	Nozzles, Rotating	30-9
CHAIN		KEROSENE HEATERS	30-19-20	Wand	30-9
Saw, Diamond	30-5	LAMPS		PROPANE HEATERS	
COMPRESSOR		Dock	30-15	Convection	30-17
Stationary	30-5	Fluorescent	30-15	Forced Air	30-16-17
CONCRETE		Incandescent	30-15	Infrared	30-18
Cutting Saws	30-2-5	Infrared Heat	30-14, 30-18	Radiant	30-18
Floor Grinder	30-4	Magnifier	30-15	PUMPS	
Floor Saws	30-3	Sodium	30-15	Effluent	30-6
Mixers	30-12	Wall Mounted	30-15	Septic Tank	30-6
CORE		Work Station	30-15	Submersible	30-6, 30-21
Drilling Machine	30-1-2	LEVEL		Sump	30-6
CUTTER		Hand	30-1	RADIANT	
Plasma	30-7	Optical	30-1	Heaters	30-18
DETERGENT		LIGHTS		SAND	
Injector	30-9	Dock	30-15	Injector	30-9
DIAMOND		Fluorescent	30-15	SAWS	
Chainsaw	30-5	Incandescent	30-15	Block	30-4
DOCK		Magnifier	30-15	Chain, Diamond	30-5
Lights	30-15	Sodium	30-15	Concrete Cutting	30-2-5
DRILLING		Wall Mounted	30-15	Floor	30-2-3
Core	30-1-2	Work Station	30-15	Hand Held	30-4
EFFLUENT PUMPS	30-6	MAGNIFIER		Hydraulic Concrete Cutter	30-4-5
FANS		Lamp	30-15	Masonry/Paver	30-4
Bench	30-13	MASONRY		Metal Cutting	30-10
Blower	30-13	Saw	30-4	Pneumatic "Quickie"	30-4
Ceiling	30-14	METAL		Walk Behind	30-2-3
Ceiling Mounted	30-13-14	Cutting Saw	30-12	SEPTIC TANK PUMP	30-16
Desk	30-13	Detector, Surveyor	30-1	SODIUM LAMP	30-15
Floor	30-13	Punching Saw	30-11	STOMPERS	30-31
Industrial	30-13-14	Working Machines	30-11-12	SUBMERSIBLE	
Oscillating	30-13	MIG		Pump	30-6, 30-21
Pedestal	30-13	Welders	30-7	SUMP PUMP	30-6
Wall Mounted	30-13	MIXERS		SURVEYORS	
Work Station	30-13	Concrete	30-12	Locator, Magnetic	30-1
FLOOR		Mortar	30-12	TENSION	
Grinder	30-4	MORTAR		Testers, Bolt	30-10-11
FLUORESCENT		Mixer	30-12	TESTERS	
Lamps	30-15	NATURAL GAS HEATERS		Bolt Tension	30-11
GENERATORS		Convection	30-17	Torque	30-11
Gas Powered	30-21	Forced Air	30-16-17	Torque-Tension	30-10-11
Welders	30-26-7	Radiant	30-18	TIMER	
GRINDER		NOZZLES		Air Control	30-11
Floor	30-4	Rotating, Pressure Washer	30-9		
HEATERS		OPTICAL			
Calculating Size	30-16	Instruments	30-1		

– continues –

SECTION INDEX

**SECTION 30
Equipment**

TORQUE WRENCH	
Calibrator	30-11
TORQUE-TENSION	
Accessories	30-11
Testers	30-10-11
WAND	
Pressure Washer	30-9
WASHER, PRESSURE	
Brush	30-9
Coldwater	30-8
Hose	30-9
Hot water	30-9
Injector, Detergent	30-9
Injector, Sand	30-9
Nozzles, Rotating	30-9
Wand	30-9
WELDERS	
Arc	30-6-7
Gas Powered	30-6-7
Generators	30-6-7
Mig	30-7
WORK STATION	
Fans	30-13
Lamps	30-15
WRENCH	
Calibrator, Torque	30-11

CST®/Diamond Products

MAGNA-TRAK 102®

Feature-Packed for Versatility! The Magna-Trak 102 magnetic locator provides the same basic performance features as the Magna-Trak 100. However, with the addition of our push-button "erase" feature, greater flexibility is achieved and performance is enhanced.

When a magnetic disturbance, such as a metal fence, is confronted, simply press the "erase" button and the disturbance is erased for continued searching without interference. No need to reduce the sensitivity; the Magna-Trak 102 always returns to perfect magnetic balance when the "erase" button is pressed.

The Magna-Trak 102 locator also includes a power line indicator feature. The LCD panel visually indicates that a power line is present. (CAUTION: This feature is an aid only and is not intended for locating buried power lines.)

19-557 Magna-Trak 102, soft case

19-558 Magna-Trak 102, hard case



CARRYING CASES FOR MAGNA-TRAK® LOCATORS

Protect your investment; our durable cases are made to last. The bright yellow Magna-Trak® soft case is constructed of padded Cordura™ nylon. Zips open and closed, includes carrying straps. Our hard cases feature a built-in handle, secure latches and textured black exterior, plus a tilt-up scabbard for easy locator removal.

19-552 Soft Padded Case for Magna-Trak Locators, yellow

19-553 Hard Case for Magna-Trak Locators

19-559 Soft Padded Case for MT-102, chartreuse



Hand Levels

All hand levels (except for 17-620) include a padded Cordura™ belt loop case.

17-620 Pocket Sighting Level
Ideal for preliminary survey and simple distance estimation. Sturdy impact resistant body and easy-to-read protected vial. Includes instruction manual. A CST/Berger best-seller! Sealed in blister pack.

17-621 Locke Hand Level
5" long square sighting tube with fixed eyepiece and a durable yellow finish. This can be used as a bench level; when supported on a staff, it is sufficiently accurate for running levels in gardening or brick lines.

17-622 Square 6" Hand Level
6" long square sighting tube with fixed eyepiece. Removable reflector unit permits right angle viewing when aperture is turned outward, and the reflector unit is placed in an inverted position in the sighting tube.

17-623 6" Hand Level
6" long with fixed eyepiece, adjustable reflector and internally mounted bubble assembly. A hexagonal objective cap prevents rolling.

17-624 6" Round Hand Level
This high quality 6" long hand level has all brass construction, a fixed eyepiece and an externally mounted bubble assembly. The hand level body is electrostatically powder painted bright safety-yellow. Hexagonal objective cap prevents rolling.



Hand Levels (continued)

17-630 5X Magnifying Hand Level

8" long round telescope tube extends to 9". The objective lens is mounted on a movable slide which brings distant objects into sharp focus; eyepiece focusing slide allows regulation of crossline image. Features 5x magnification of objective and 2x magnification of level bubble, solid brass construction with a durable yellow finish, and 1:100 stadia lines.



17-631 2X Magnifying Hand Level

6" long with draw eyepiece extending to 8". Adjustable reflector and internally mounted bubble assembly.



17-632 K & E Type 2X Hand Level

2X magnification with all brass construction. Features 6" long draw eyepiece extending to 7-1/2", adjustable reflector and internally mounted bubble assembly.



Diamond Products

CORE RIGS:

M-1 Drill Rigs

The #1 Drill Rig In America

- 1" to 10" bit capacity (14" with one spacer)
- Dual switch/outlet control panel & amp meter
- Slide handle permits drilling in tight areas
- Streamlined base and carriage
- 2-1/2" square column with black oxidized finish
- Quick changeover from vacuum to anchor base
- 6" wheels for better mobility

Order complete:

Our combination rig includes a combination anchor/vacuum base, mast, carriage, control panel, vacuum pump, ceiling jack, motor mount plate and your choice of drill motor. Our anchor rig is the same as above except for its smaller anchor base and does not include a vacuum pump. Select from P/N's listed below.

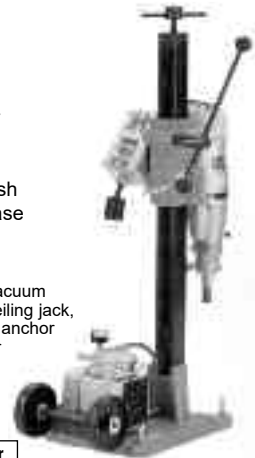

Motor	RPM	Safety Override	Combo Rig P/N	Anchor Rig P/N
20 Amp Dewalt	350/900	Slip Clutch	4245055	4545001

M-1 Drill Stand Dimensions		
	Anchor Stand (in)	Combination Stand (in)
A	43-3/4	44-1/4
B	23-1/2	28-1/2
C	6	13-1/2
D*	24-1/4	24-1/4
E*	5-5/8	5-5/8
F	11	17
G	16	23

* For Dewalt motors.

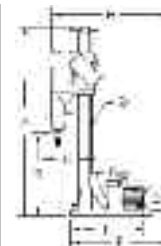

- continues -

Equipment

Diamond Products

M-2 Drill Rig

The #1 Pro Rig in America

- Dual switch/outlet control panel & amp meter
- 4 spoke handle
- Precision ground & chrome plated 2-7/8" square mast
- Quick changeover from vacuum to anchor base
- 10" bit capacity (up to 36" with spacers and a hydraulic motor and pillow block)
- 6" wheels for better mobility

Order complete:

Our combination rig includes a combination anchor/vacuum base, mast, carriage, control panel, vacuum pump, ceiling jack, motor mount plate and your choice of drill motor. Our anchor rig is the same as above except for its smaller anchor base and does not include a vacuum pump. Select from P/N's listed below.

Motor	RPM	Safety Override	Combo Rig P/N	Anchor Rig P/N
20 Amp Dewalt	350/900	Slip Clutch	4241050	4541001

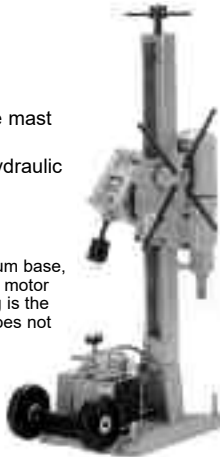

M-2 Complete Combination Rig

M-2 Drill Rig Dimensions			
	Anchor Stand (in)	Combo Stand (in)	Large Anchor (in)
A	44	44	44
B	23-3/4	28-1/2	27
C	7	13-1/2	15
D	23-1/2	23-1/2	23-1/2
E	5-1/2	5-1/2	5-1/2
F	12-1/4	17	18-1/2
G	17-1/4	23	20-1/2

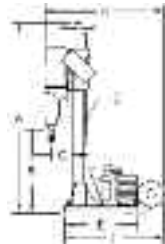

M-4 Rig

3 Speed, Very Powerful & Just 35 lbs.

- Weighs only 35 lbs. (rig - 20 lbs., motor - 15 lbs.)
- 6" bit capacity (3" handheld)
- Converts to hand held drill motor in seconds
- Combination stand quickly angles to 45°
- 3-speed hand held drill motors with overload clutches are available with choice of 110V electric, 220V electric, air or hydraulic power
- Mast can rotate 360° on swivel stand
- Reversible slide handle (use on left side or right side of rig)
- High strength, hard anodized, 1-1/2" x 2" aluminum column
- 4 adjustable slide bearings provide superior carriage rigidity
- Carriage lock

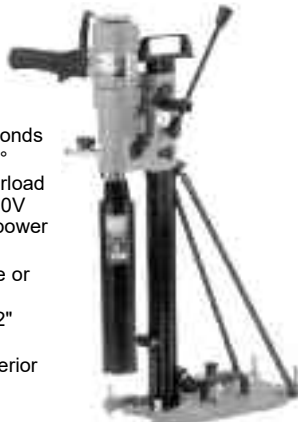

M-4 Complete Combination Rig



- A Reversible slide handle
- B Carriage lock
- C Adjustable slide bearings
- D Handheld motor quick release



- A Centering Pointer
- B Lifting Handle
- C Quick vacuum release valve
- D Locking slot cap
- E Depth Stop



The WEKA DK12 Hand Held Drill works well with our thinwall handheld bits

M-4 Drill Rig Dim.	
Combo Stand In.	
A	33-1/8
B	19-3/4
C	7-7/8
D*	21-3/8
E*	3-5/8
F	16-7/8

*For WEKA motor.

M-6 Drill Stand

Quit wrestling with big bits on small rigs. The M-6 Rig makes drilling large diameter holes faster and safer.

- 2:1 gear reduction makes easy lifting of larger bits
- 18-inch bit capacity with standard pillow block
- Optional 4" x 6" steel tube spacers for drilling up to 72" diameter holes
- Available hydraulic pillow block and extensions with 1-7/8"-7 or 1-1/4"-7 threads for high torque drilling
- Heavy duty 15" x 12" roller carriage
- Equipped with a beefy 72" tall 4" x 6" rectangular mast
- Sturdy cast aluminum base
- 6" rubber tread cast-iron wheels with roller bearings



The M-6 large bit drilling system shown with drill stand, tube spacer, hydraulic pillow block, hydraulic motor and bit extension (drill stand part no. 4277581)

M-6 Drill Stand Only	
Description	P/N
Large anchor stand w/ wheels & quick disconnect motor mounted plate	4277581

M-6 Drill Stand
Height = 72", 96" or 120"
Length = 23"
Width = 19" (wheel to wheel)

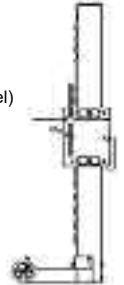

Please note that the Pillow Block and hydraulic motor must be ordered separately.

Use P/N 4277539 for 1-1/4-7 spindle.

Use Pillow Block P/N 4277540 for 1-7/8-7 spindle for use on bits 30" and up.

DIAMOND SAWS

CORE CUT - CONCRETE SAWS:

CORE CUT® Concrete Saw Specifications*:

Model No.	Max Engine (HP)	Blade Guard Cap (in)	Max Depth of Cut (in)	Blade Shaft Size (in)	Arbor Size (in)
CC1100	13	14	4-5/8	ø 1"	ø 1"
CC1300	13	14 - 18	6-5/8	ø 1-1/4"	ø 1"
CC1800	20	14 - 20	7-5/8	ø 1-1/4"	ø 1"
CC2500	25	14 - 26	10-3/8	ø 1-1/2"	ø 1"
CC3500	35	14 - 30	11-3/4	ø 1-3/4"	ø 1"
CC3700	37	14 - 36	14-3/4	ø 1-3/4"	ø 1"
CC6500	65	14 - 36	14-3/4	ø 1-3/4"	ø 1"
CC7100	72	14 - 42	16-3/4	ø 2"	ø 1"
CC7200	72	26 - 54	22-3/4	ø 2"	ø 1"
CC8000	72	14 - 54	22-3/4	2-1/2"	ø 1"

* Please call for further specifications on these & other saws

CC1100 Series:

- Our patented ratchet raise & lower system is the fastest, easiest way to place the blade into & out of the cut. It has 11 depth settings to choose from which automatically lock in place when the handgrip is released. Settings are in 1/2" increments.
- Removable handles for easy storage.
- Blade coolant is delivered from an innovative dual multi spray water tube system which gets coolant to both sides of the blade from the arbor to the top of the blade
- Power transmission to blade drive is via 3 molded notch 3VX premium belts – not 2, like some of our competitors, resulting in better cutting performance & longer belt life.
- Self aligning blade shaft bearings
- 4-5/8" cutting depth w/14" guard
- Large wheels for easy mobility over curbs & rough surfaces



CC1100 Series

Diamond Products

CC1300 Series :

Compact, Portable & Rugged

- Screw feed or patented ratchet raise & lower mechanism
- Upcut models available
- Left or right hand sawing
- Self aligning blade shaft bearings
- Available w/choice of 14" or 18" blade guard. 6-5/8" cutting depth w/18" guard
- Handle adjusts to saw operator's height
- * Many gasoline & electric power sources to choose from
- * Handle folds down for easy storage & transport



CC1300 Series

CC1800 Series :

Large Saw Features in a Portable Saw

- Screw feed raise & lower mechanism
- Available w/push or hydrostatic transmission choices.
- Variety of power options in gasoline, electric or hydraulic up to 20 HP
- Left or right hand sawing
- Self aligning blade shaft bearings
- Available with choice of 14" or 20" blade guard. 7-5/8" cutting depth w/20" guard
- Available with a 10 HP electric motor
- Handle adjusts to saw operator's height.
- * Blade drive is via 4 belts on 16 HP models & up. 14 HP models & below have 3 belts.



CC1800 Series

CC2500 Series :

Delivers the Power of a Large Saw with the compactness & economy of a Small One!

- Economical screw feed raise & lower mechanism
- Variety of engine options up to 25 HP
- Rigid high strength box frame
- Positive gear drive to rear axle via Eaton hydrostatic transmission
- Large 5-gallon fuel capacity for longer sawing between refills
- Choice of 14", 20" or 26" slip-on blade guards
- Maximum cutting depth 10-3/8" with a 26" guard



CC2500 Series

CC3500 Series:

35 HP Service Saw

- Utilizes many of the same heavy-duty components we use on our bigger saws
- Features Wisconsin 35 HP gasoline engine
- Available w/a 20 HP or 30 HP electric motor.
- Maximum cutting depth 11-3/4" with a 30" guard
- Choice of 14" through 30" blade guards
- Fits through a 30" door!
- * CORE-CUT® large saws feature convenient one hand saw control



CC3500 Series

CC3700 Series:

Multi-Application Saw

The most Compact 65 HP Saw on the Market - Fits through a 30" Door!

- One hand sawing control.
- Features 37 HP or powerful 65 HP Wisconsin gasoline engines (also available w/ 28 HP Deutz Diesel engine)
- Choice of 14" through 36" blade guards. Maximum cutting depth 14-3/4" with a 36" guard
- Available w/a 25 HP or 40 HP electric motor.
- Has a frame designed for the higher torque of a large horsepower engine but more compact than the CC6500
- * CORE CUT® large saws have the best bearings, blade flanges and blade shafts in the business.

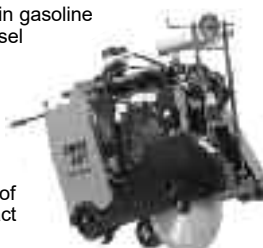

CC3700 Series

CC6500 Series:

- One hand sawing control
- Features Wisconsin 65 HP gasoline engine
- Choice of 14" through 48" blade guards
- Available with a 30 or 40 HP electric motor
- Maximum cutting depth 14-3/4" w/36" guard (19-3/4" w/optional 48" conversion kit)
- Fits through a 36" door
- * CORE CUT® frames are the best in the business, which improves your blade cutting speed and life.

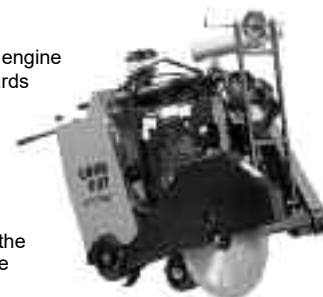

CC6500 Series

CC7100 Series:

Turbo Charged Diesel Production Concrete Saw

- Longer life lower maintenance engine than 65 HP gasoline engine
- Features Deutz 72 HP turbo charged engine.
- 16-3/4" cutting depth w/42" guard
- Extra heavy-duty reinforced single piece frame
- Choice of 14" through 42" blade guards
- Better fuel economy and much higher sawing rates than a normal 65 HP gasoline engine.
- * Comes standard with CORE CUT's® Shaft Tachometer.

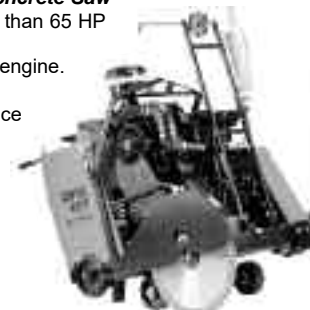

CC7100 Series

CC7200 Series :

Turbo Charged Diesel Deep-Cut Saw

- Features Deutz 72 HP turbo charged engine
- Extra heavy-duty reinforced single piece frame.
- Available with a 40 HP or 50 HP electric motor.
- 22-3/4" cutting depth with 54" guard
- Choice of 26" through 54" blade guards
- Longer life lower maintenance engine than 65 HP gasoline engine.
- * Comes standard with CORE CUT's® Shaft Tachometer



CC7200 Series

CC8000 Series Rider Concrete Saw:

Revolutionary New Concept That Delivers Maximum Flexibility

- Hydraulic-driven blade shaft delivers an infinitely variable RPM with no horsepower loss for 14" to 54" blade diameters.
- Accommodates 14" through 54" blade.
- Arm-mounted blade raises and lowers easily (while engine and operator remain level)
- Arm can be rotated for blade to enter cut at up to a 20° angle
- 22-3/4" cutting depth with 54" guard
- Less operator fatigue with low maintenance and easy serviceability.
- Converts from a downcut to an upcut saw in less than a minute.
- Heat exchanger for hydraulic oil utilizes air for cooling
- 72 HP Deutz Standard



CC8000 Series

Equipment

Diamond Products

Air Saws/Floor Grinders

The AirMatic 500 (Hand-Held) and AirMatic 700 (Walk-Behind) Dry Cutting Pneumatic Saws are the Logical Alternatives to:

- Clean, quiet and dependable
- Lockable, multi-position blade guard
- Quick change blade adapter
- Direct drive - no belts



Airmatic Saws				
Model No.	Engine Type	Part No.	Blade Cap. (in)	Uncrafted Wt. (lbs)
Airmatic 500 (hand-held)	4 HP Air	5800076	14"	22
Airmatic 700 (walk-behind)	4 HP Air	5800077	14"	50

AirMatic Saw Accessories	
Description	Part No.
Cart (for Airmatic 500) w/o Dust Suppression	5800078
Cart (for Airmatic 500) w/Dust Suppression	5800139
Water Kit (for wet cutting)	6048421
1 qt. Ice Free Oil	6048427

Floor Grinder

- Takes rough spots out of concrete surfaces in a hurry. Ideal on floors, roads, bridges, sidewalks and patios.
- Cleans levels and smooths bumps and uneven areas. Removes paint spots and epoxies. Maneuverable and easy to operate.
- Compact and easily adjustable for all types of cleaning, grinding and feathering.
- Large 10" diamond grinding head covers large surface areas in minutes.
- 10" diamond heads available with 10 or 20 segments (Available in Heavy Duty Orange or Premium Black grades)



Floor Grinders				
Model No.	Engine Type	Part No.	Head Cap. (in)	Uncrafted Wt. (lbs)**
CB-CG8	8 HP Briggs	5800023	10	227
CB-CG75	7.5 HP - 1 PH 230V Electric	5800111	10	300
CB-CG75	7.5 HP - 3 PH Electric*	5800133	10	300

*Specify 230V or 460V. 575V motors available on request. 50 cycle motors also available.
** Add 40 pounds for crated weight.

Block Saws (CC1000 Series)

For the Masonry Contractor who Demands Productivity, Convenience and Safety

- 20" Blade capacity cuts an 8" x 8" x 16" concrete block in a single pass
- Foot pedal controlled operating head leaves operator's hands free to guide material being cut
- Heavy duty forklift brackets provide ease of movement with added safety
- Stay-level blade guard with flange safety cover and cast-in water system assure blade is covered at all times
- Totally enclosed blade shaft with dual bearing alignment
- Precision screw feed raise and lower mechanism assures proper depth of cut



Model No.	Engine Type	Part No.	Blade Cap. (in)	Uncrafted Wt. (lbs)
CC1051 Block	5 HP - 1 PH Electric	5800027	20	355
CC1053 Block	5 HP - 3 PH Electric	5800028	20	365
CC1073 Block	7.5 HP - 3 PH Electric	5800029	20	395
CC107G Block	7.5 HP Wisconsin Gas	5800030	20	408

Masonry/Paver Saws (CC500M & CC400M)

All That The Competitors Offer And More, For Less

- Legs standard on all saws
- Water pump standard on all electric models
- Easy, safe access to depth control lock
- Cooler running electric motors
- 2.5 HP electric motor is strongest dual-voltage motor on the market
- Stay level guard
- Removable head
- Open throat cutting
- Electric or optional Honda 5.5 HP gas power
- Side carrying



CC500M Masonry Saws and CC400M Paver Saws				
Model No.	Power Source	Part No.	Wt.(lbs)**	
CC515M-E1	1.5 HP Baldor-115/230V Electric*	5800373	194	
CC525M-E1	2.5 HP Baldor-115/230V Electric*	5800375	194	
CC555M-H	5.5HP Honda	5800376	172	
CC415M-E1	1.5 HP Baldor-115/230V Electric*	5800377	225	
CC425M-E1	2.5 HP Baldor-115/230V Electric*	5800378	220	
CC455M-H	5.5 HP Honda	5800379	210	

*All electric motors are single phase.
**Add 25 lbs. for crated weight.

CC525M-E1 (shown w/optional stand)

CC500M/CC400M Dimensions			
Dimension	CC500M*	CC400M**	
A Saw Length	34"	36-3/4"	
B Saw Width	24-3/4"	24-3/4"	
C Saw Height	32-7/8"	28"	
D Stand Height	27"	27"	
E Total Height	58-3/8"	53-1/2"	
F Arbor Height	15-3/8"	6-3/4"	
Over Cart			
G Cart Travel	20-3/4"	20-3/4"	

*Dimensions for CC500M are with electric motor with cutting head raised to maximum height.
**Dimensions for CC400M are with gasoline engine.

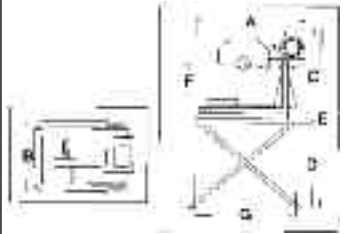

Hydraulic Hand Held Saw

- Delivers cutting depths up to 8"
- Light weight, all-aluminum construction
- Hydraulic powered for smooth, low vibration operation
- Lower noise and less maintenance than comparable gas powered circular saws
- Width of our .235 wide cutting blade matches our Diamond Chain Saw (just corner cut with the chain saw and save wear and tear on both saws!)
- Water flow controlled through handle and runs only when the power is on!
- Works with our multi-flow power pack and many other types of hydraulic power units
- Built in flow restrictor keeps saw at optimum speed and prevents blade overspeeding
- Built in roller base for easy maneuverability

16" Saw Specifications	
DP Part# 5800509	
Max. Depth of Cut	6"
Blade Arbor Diameter	1"
Max. Operating Pressure:	2500 psi (172 bar)
Max. Flow Rate:	10-gpm/38 liters/min.
Max. Blade RPM:	3,100
Weight (uncrated):	27 lbs.
Dimensions:	Surface "A" = 18 Width "B" = 7-1/4" Length "C" = 25" Roller to Roller "D" = 19-3/4" Height "E" = 11-3/8"



20" Saw Specifications	
DP Part # 5800510	
Maximum Depth of Cut	8"
Blade Arbor Diameter	1"
Max. Operating Pressure:	2,500 psi (172 bar)
Max. Flow Rate:	8-gpm/30 liters/min.
Max. Blade RPM:	2,450
Weight (uncrated):	32 lbs.
Dimensions:	Surface "A" = 22" Width "B" = 7-1/4" Length "C" = 29" Roller to Roller "D" = 23-3/4" Height "E" = 13-3/8"

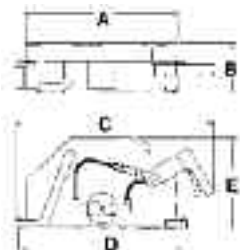

Diamond Products

Diamond Chain Saw

- Eliminates overcuts
- Light weight, portable (weighs just 41 pounds) and ideal for working in tight spaces and openings
- Great for deep cutting, irregular shapes, angles, corner and plunge cuts
- Flush cuts within 1 inch of walls
- Available in 15" & 19" Bar Sizes



Chain Type	Material	Rebar*
Concrete Chain	Reinforced Concrete Medium Aggregate Cured Concrete	up to 5/8"
Chain for Abrasives Materials	Masonry Brick Concrete Block Soft Natural Stone Abrasive Concrete Light Steel Reinforcing	up to 1/4"
Premium Chain	Reinforced Concrete Very Hard Aggregate	up to 1-1/4"

*Spacing of steel or rebar will affect cutting performance

Diamond Chain Saw Accessories	
Part No.	Description
5802223	Hydraulic Powerhead (including carrying case)
5802224	Multi Flow Power Pack
6048610	15" Bar
6048611	19" Bar
6048612	8GPM Hydraulic Flow Adapter Kit
6048613	Electric Water Booster Pump Assembly
6048631	15" Chain - 33 seg
6048632	19" Chain - 39 seg
6048633	15" Abrasives Chain - 33 seg
6048634	19" Abrasives Chain - 39 seg
6048635	15" Premium Chain - 33 seg
6048636	19" Premium Chain - 39 seg
2600048	18 HP Briggs Vanguard 2 Cylinder Hydraulic Pump*
2600184	65 HP Wisconsin V465D Hydraulic Pump*
2600117	80 HP John Deere Diesel Hydraulic Pump*

*Flow on this hydraulic pump must be reduced to 8 gallons per minute

Diamond Chain Saw Specifications	
823H Power Head*	DP Part # 5802223
Bar Cutting Depths:	15 and 19"
Hydraulic Supply Requirements:	
Flow (max):	8 gpm (30 liters/min.) 2500 psi (172.5 bar)
Note: For fixed-flow hydraulic systems producing more than 8 gpm (30 liters/minimum) use DP Model 70350 Flow	
Adapter Valve	
Operating Speeds:	
	4,600 rpm motor speed (free running) 4,000 sfm average chain speed (free running)
Water Supply Requirements:	
	Minimum 2 gpm (7.5 liters/min.) from cutting bar Recommended 80 psi (5.6 bar) on saw gauge
Noise Level:	
	88 dB at 3 feet (1 meter) Much quieter than gas powered saws!
*Bar and chain not included with power head. These items must be purchased separately	

When purchasing isn't an option... RENT the equipment you need!

Why RENT?

- **Performance** - no need to worry, our rentals are serviced and maintained to guarantee performance.
- **Reduced Overhead** - renting eliminates the need for equipment storage and maintenance areas.
- **Reduce Downtime** - keep projects on schedule when equipment goes down.
- **Demo Equipment** - try out equipment before you decide to buy.

We have a large selection of equipment where and when you need it.

Reliable, Dependable, and Ready to Work!

Call our rental division for more information **716.826.2636**

Equipment

Little Giant Pump Co./Miller

Water Wizard® Submersible Pumps

5 Series

Includes garden hose adapter and removable inlet screen for easy cleaning. Lifetime oil supply. Pumps down to 1/8".

5-MSP	Manual
505000.....	115V 10' power cord
505086.....	115V 10' power cord
505176.....	115V 18' power cord
505025.....	115V 25' power cord
505500.....	127V 10' power cord
505501.....	127V 18' power cord
505202.....	230V 12' power cord

5-MSP



5-MSPR	Manual
505486.....	115V 10' power cord

Motor	1/6 HP Shaded Pole
Max. flow rate	1200 GPH @ 1'
	4542 LPH @ 30cm
Max. Head	26.3'
Intermittent Liquid	
Temp. to	120°F
Discharge	1" FNPT
Housing.....	Epoxy coated cast aluminum
Volute.....	Nylon
Impeller.....	Nylon
Shaft Seal.....	Viton®
Shaft	Stainless Steel
Operation	Manual

Electrical	
505000	115V, 60Hz, 5 amps 10' power cord
505086	115V, 60Hz, 5 amps 10' power cord
505176	115V, 60Hz, 5 amps 18' power cord
505025	115V, 60Hz, 5 amps 25' power cord
505500	127V, 60Hz, 5 amps 10' power cord
505501	127V, 60Hz, 5 amps 18' power cord
505202	230V, 60Hz, 5 amps 12' power cord
505486	115V, 60Hz, 5 amps 10' power cord

Potent® Pump Accessories

PPIK-1

155201 Replacement kit for PP-1. Impeller, cam and gasket.



Sump Pumps

6E Series

6E-CIA-SFS	Automatic
506700.....	115V 10' power cord
506701.....	115V 25' power cord
506720.....	230V 15' power cord

6E-CIA-RFSN	Manual or Automatic
506740.....	115V 10' power cord

6E-CIA-SFS



Motor	1/3 HP Shaded Pole
Max. Flow Rate.....	50 GPM @ 5'
	189 LPM @ 1.52m
Max. Head	20'
Solids handling.....	1/2"
Intermittent Liquid	
Temp. to	140°F
Discharge	1-1/2" FNPT
Housing.....	Epoxy coated cast iron
Cover	Polycarbonate
Volute.....	Polypropylene/Cast Iron
Impeller	Nylon
Shaft Seal.....	Carbon/Ceramic
Bearings	Upper & Lower Sintered sleeve bearings

Activator	
6E-CIA-SFS	"Snap-Action" Float Switch
6E-CIA-RFSN.....	Piggyback mechanical float switch
Switch on	Switch off
7" - 10"	2" - 5"
Electrical	
506700.....	115V, 60Hz, 10 amps 10' power cord
506701.....	115V, 60Hz, 10 amps 25' power cord
506720.....	230V, 60Hz, 4.8 amps 15' power cord
506740.....	115V, 60Hz, 10 amps 10' power cord

Operations	
6E-CIA-SFS	Automatic
6E-CIA-RFSN.....	Manual or Automatic

Onsite Septic Tank Effluent Pumps

10E Series

10E-CIA-SFS	Automatic
511350.....	115V 10' power cord
511355.....	115V 25' power cord

10E-CIA-SFS



Motor	1/2 HP Permanent Split Capacitor
Max. flow rate.....	80 GPM @ 5' 303 LPM @ 1.52m
Max. Head	24'
Solids handling.....	3/4"
Intermittent Liquid	
Temp. to	140°F
Discharge	1-1/2" FNPT
Housing.....	Epoxy coated cast iron
Cover.....	Polycarbonate
Volute.....	ABS/Cast iron
Impeller.....	Vortex Nylon
Shaft Seal.....	Carbon/Ceramic

Bearings	Upper & lower: Ball bearings
Operation	Automatic
Activator	Integral "Snap Action" float switch
Switch on	Switch off
8" - 11"	2" - 5"
Electrical	
511350.....	115C, 60Hz, 8.2 amps 10' power cord
511355.....	115V, 60Hz, 8.2 amps 25' power cord

Miller®

ENGINE-DRIVEN WELDING GENERATORS

Blue Star® 3500

The Blue Star® 3500 is a compact welding and auxiliary power generator designed for applications where portability and versatility are essential. This unit is ideal for construction, maintenance and agriculture applications.

Features

- 140 amps DC welding output
- Smooth and stable three-phase welding output
- Excellent DC Stick performance with 1/8 – 5/32 in electrodes
- 3500 watts of auxiliary power
- Compact, portable unit protected by a durable steel frame
- Color-coded amperage control
- Powered by 9 HP Honda gasoline engine
- Manual and electric start models available

Processes

- DC Stick (DC SMAW)
- DC TIG (DC GTAW)

Engine

- Honda GX270 gasoline engine, 9 HP at 3600 RPM
- 1-cylinder, 4-cycle, OHV air-cooled
- Manufacturer's 2-year warranty



Accessories

Lifting Eye; Running Gear: No. 24HI; Stick Accessory Kit: No. 2WA. Call for further information on field options.

Rated Output	Amperage Range	Single-Phase Auxiliary Power	Dim. (in)	Wt. (lbs) Recoil Start	Wt. (lbs) Electric Start
140 A, 25 V at 30% Duty Cycle	40 – 140	3500 watts	H: 20-3/4 W: 22-3/4 D: 31-1/4	Net: 201 Ship: 225	Net: 226 Ship: 250
100 A, 25 V at 60% Duty Cycle		26 A at 115 V while not welding			

Miller®

Blue Star® 6000

The Blue Star® 6000 is a compact welding and 6000-watt auxiliary power generator designed for light industrial Stick welding and maintenance applications. This portable unit is capable of producing AC auxiliary power even while welding.

Features

- 180 amps DC welding output
- Ideal DC Stick performance with 3/32 – 3/16 in electrodes
- 6000 watts of auxiliary power
- Color-coded amperage control
- 120V and 230V auxiliary power available
- Powered by 13 HP Honda gasoline engine
- Manual and electric start models available

Processes

- DC Stick (DC SMAW)
- DC TIG (DC GTAW)

Engine

- Honda GX390 gasoline engine, 13 HP at 3600 RPM
- 1-cylinder, 4-cycle, OHV air-cooled
- Manufacturer's 2-year warranty



Accessories

Lifting Eye; Running Gear No. 24HI; Stick Accessory Kit: No. 2WA. Call for further information on field options.

Rated Output	Amperage Range	Single-Phase Auxiliary Power	Dim. (in)	Wt. (lbs) Recoil Start	Wt. (lbs) Electric Start
180 A, 25 V at 30% Duty Cycle	40 – 180	6000 watts, peak 5500 watts, cont. while not welding	H: 20-3/4 W: 22-3/4 D: 31-1/4	Net: 253 Ship: 277	Net: 278 Ship: 302
100 A, 25 V at 100% Duty Cycle					

Bobcat™ 225 NT

Introducing the Bobcat™ 225 NT, a new tradition (NT) in portable engine driven welding generators. We added a series of innovative features to this 8000-watt unit to meet the demanding multi-purpose needs that contractors face on the job site.

The Bobcat 225 NT is also the first-and-only engine driven welding generator to offer an optional, cordless remote start/stop control. This exclusive remote control saves you time and money.

- You can easily shut off the engine when not in use – saves up to 20% on fuel consumption
- Remote control works with your weld cables (up to 300 feet away from engine)
- Increase time between maintenance intervals by up to 200%
- Simple, convenient operation; durable hand-held control



Processes

- AC/DC Stick (AC/DC SMAW)
- Flux Cored (FCAW)
- MIG (GMAW)
- Non-critical TIG (GTAW)

Engine

- Onan Performer Series P216 industrial gasoline engine
- Manufacturer's 3-year warranty (not limited by engine running time)
- Kohler Command 18 gasoline engine
- OHV design is compact, quiet and 30% more fuel efficient
- Replaceable steel cylinder liners, hydraulic lifters, and full pressure lubrication
- Manufacturer's 2-year warranty



Suggested Wire Feeders

Super S-32P; Spoolmatic® 30A and WC-115 Control for aluminum.

Accessories

Plasma Cutters: Spectrum® 300 CutMate™ or Spectrum® 650 CutForce™; Cylinder Rack; Running Gear: No. 48 or No. 27; Canvas Cover: CC-1A; Trailer: AP 210; TIG High-Frequency Arc Starter: HF-25ID-1. Call for information on LP Gas Conversion, Battery Charging Kit, Stainless Steel Case, GFCI 120 V Receptacle and Spark Arrestor Muffler.

– continues –

Bobcat™ 225 NT (continued)

Rated Output at 100% Duty Cycle	Max Open-Circuit Voltage	Amp. Ranges CC/AC CC/DC	Auxiliary Power	Dim. (in)	Net Wt. (lbs)
CC/AC: 225 A at 25 V	80 VAC	50-100 50-100 70-150 70-150	8kW/kVA, 120/240 VAC, 60 Hz, 70/35 A, while not welding	H: 33 W: 18-3/4 D: 45-1/2	Onan: 573 Kohler: 565
CC/DC: 210 A at 25 V	80 VDC	85-225 85-210			
CV/DC: 200 A at 20 V (17 - 28 Load V)	33 VDC				

Engine Specifications:

Engine Brand	Horse-power (HP)	Type	Weld Speed (RPM)	Idle Speed (RPM)	Fuel Cap. (gal)	Oil Cap. (qt)
Onan	16 HP at 3600 RPM	Twin cylinder, 4-cycle, "L-head", industrial, air-cooled, gasoline	3700	2200	10	1.5 qt; 1.75 qt. w/filter every 100 hours
Kohler	18 HP at 3600 RPM	Twin cylinder, 4-cycle, overhead valve, industrial, air-cooled, gasoline	3700	2200	10	1.75 qt; 2 qt. w/filter every 100 hours for oil - every 200 hrs for oil filter

PLASMA CUTTERS

Spectrum® 300 CutMate

The Spectrum® 300 CutMate is an economical plasma cutting system for work on all conductive metals including mild steel up to 3/8 in, aluminum to 1/4 in, and stainless steel to 5/16 in. Solid-state design and Miller's reliable technology packs a lot of performance into a very portable, 42 lb package. The CutMate is ideal for maintenance, light construction, prototyping, body shops, fabrication and HVAC ductwork

Simplified internal parts eliminate the need for high-frequency starts, making the CutMate an excellent machine when high-frequency noise can interfere with nearby control systems or computers. This versatile power source adapts to your shop or work site by operating from either 115 or 230 VAC power.

Features:

- Diagnostic fights for quick troubleshooting
- Convenient front panel consumables compartment
- Torch airflow design allows drag cutting without a standoff
- Controlled pilot arc allows you to cut grates, chain link fence and other perforated metals, as well as painted or coated surfaces, without retriggering the gun.
- Exclusive postflow circuit cools consumables and torch to extend life



Process:

- Air Plasma Cutting

Comes complete with:

- ICE-25C torch with 15 ft. or 25 ft. cable, full 1-year warranty
- 15 ft. work cable with clamp
- 10 ft. power cord with 115VAC, 20 A plug
- Built-in gas/air filter and regulator with extra protection

Accessories

Cable Covers; Torch: ICE-25. Call for information on torch consumables, Power Source Mounting Bracket, Full KVA Plug Kit and 115 V Receptacle and Plug Kits.

Models*	Rated Output at 35% Duty Cycle	Max. Open-Circuit Voltage	Amps Input at Rated Load Output, 60 Hz		Plasma Gas Flow/Pressure	Dim. (in)	Wt. (lbs)	
			115V	230V				KVA
230V	20 A w/115 VAC input power, 20 A input circuit	265 VDC	34	17	3.95	3.1	4.5 CFM at 60 PSI	H: 17 W: 18 D: 6-3/4
115/230V	25 A w/115 VAC input power, 30 A input circuit							
	25 A w/230 VAC input power							

* Models listed include 15 ft. hand torch – 25 ft. torch available

Equipment

Mi-T-M®

Mi-T-M®

INDUSTRIAL PRESSURE WASHERS

Cold Water CD Series

Electric Direct Drive Features:

- Totally enclosed fan-cooled electric motors with manual thermal overload protection
- Direct-drive triplex piston pumps with ceramic plungers
- Forged brass manifold
- Stainless-steel and brass unloader
- Adjustable pressure on OMUH and OMUC models
- 35-ft. power cord (20 amp plug on CD-1502 models) with ground fault circuit interrupter (GFCI)
- Built-in detergent injection
- Pressure relief valve on OMUH and OMUC models
- Thermal relief valve
- In-line water strainer
- Powder coated steel mounting plate with center balanced lift and four rubber isolators on hand carry models
- 25-ft. steel wire-braided pressure hose with quick connects and bend restrictors
- Professional-grade trigger gun with safety lock-off
- OMUH and OMUC units have a variable high/low pressure nozzle with adjustable spray pattern (0-60 degrees)
- 1 MUH and 1 MUC units have a 15-degree high/low pressure nozzle
- Powder coated steel frame (on cart mount)
- Semi-pneumatic tires (on cart mount)
- Hose wrap and gun/wand holder (on cart mount)
- One-year limited parts and labor warranty
- Five-year pump warranty



CD-1002-MUH

Model	PSI/ bar	GPM/ lpm	HP	Voltage/ Phase	Unit Dim. L x W x H (in)	Net. Wt. (lbs)
DC-1002-0MUC	1000/69	2.0/7.6	1.5	120V/10	30.5 x 16.5 x 23	75
CD-1002-0MUH	1000/69	2.0/7.6	1.5	120V/10	25 x 15.5 x 16.5	63
CD-1002-1MUC*	1000/69	2.0/7.6	1.5	120V/10	30.5 x 16.5 x 23	75
CD-1002-1MUH*	1000/69	2.0/7.6	1.5	120V/10	25 x 15.5 x 16.5	63
CD-1502-0MUC	1500/103	2.0/7.6	2.0	120V/10	30.5 x 16.5 x 23	80
CD-1502-0MUH	1500/103	2.0/7.6	2.0	120V/10	25 x 15.5 x 16.5	67
CD-1502-1MUC*	1500/103	2.0/7.6	2.0	120V/10	30.5 x 16.5 x 23	80
CD-1502-1MUH*	1500/103	2.0/7.6	2.0	120V/10	25 x 15.5 x 16.5	67

Accessory cart AW-7005-02WK available.
* Pump handles incoming water up to 180 degrees.

Cold Water CW Series

Gasoline Belt Drive Features:

- Performance-proven OHV engines with low-oil protection
- Triplex ceramic plunger pump with forged-brass manifold
- Thermal relief valve
- Stainless-steel and brass unloader
- Large capacity bowl-type water strainer
- Cogged belt drive system and cast-iron pulleys
- Two-piece belt guard with 1/4-turn release for quick access to belts
- 1/4 in. powder coated steel base plate
- Solid-steel axle
- Pneumatic tires
- Rubber isolators
- Powder coated steel tube handles
- Hose wrap with gun/wand holder
- 50-ft. steel wire-braided pressure hose with quick connects and bend restrictors
- Professional-grade trigger gun with safety lock-off
- 36-in. steel lance with rubber grip
- Quick connect nozzles (0, 15, 25, 40 degrees)
- Electric start on 16 HP Vanguard (optional 11 and 13 HP engines)
- Two-year limited parts and labor warranty
- Five-year pump warranty



CW-3004-3MGH

Cold Water CW Series (continued)

Model	PSI/ bar	GPM/ lpm	HP	Engine	Unit Dim. L x W x H (in)	Net. Wt. (lbs)
CW-1504-3MGH	1500/103	3.4/12.9	5.5	OHV Honda	40 x 32.5 x 25.5	124
CW-1504-3MGV	1500/103	3.4/12.9	6.0	OHV Vanguard	40 x 32.5 x 25.5	126
CW-2003-3MGH	2000/138	2.8/10.6	5.5	OHV Honda	40 x 32.5 x 25.5	124
CW-2003-3MGV	2000/138	2.8/10.3	6.0	OHV Vanguard	40 x 32.5 x 25.5	126
CW-2008-0MGV	2000/138	8.0/30.3	16.0	OHV Vanguard	45.5 x 32.5 x 30	306
CW-2504-1MKB	2500/172	3.6/13.6	9.5	OVH Kawasaki	48.5 x 35.5 x 30.5	175
CW-2504-4MHO	2500/172	3.6/13.6	9.0	OHV Honda	48.5 x 35.5 x 30.5	160
CW-2504-4MVO	2500/172	3.6/13.6	9.0	OHV Vanguard	48.5 x 35.5 x 30.5	163
CW-2505-3MGH	2500/172	4.4/16.7	11.0	OHV Honda	48.5 x 35.5 x 30.5	212
CW-2505-3MGV	2500/172	4.4/16.7	11.0	OHV Vanguard	48.5 x 35.5 x 30.5	212
CW-3004-1MKB	3000/207	3.9/14.8	11.5	OHV Kawasaki	46 x 27 x 24	185
CW-3004-3MGH	3000/207	3.5/13.3	11.0	OHV Honda	46 x 27 x 24	212
CW-3004-3MGV	3000/207	3.5/13.3	11.0	OHV Vanguard	46 x 27 x 24	212
CW-3255-3MVO	3200/221	5.1/19.3	16.0	OHV Vanguard	46 x 27 x 24	236
CW-3504-3MGH	3500/241	3.5/13.3	13.0	OHV Honda	46 x 27 x 24	220
CW-3504-3MGV	3500/241	3.5/13.3	13.0	OHV Vanguard	46 x 27 x 24	220
CW-4003-3MGH	4000/276	3.0/11.4	13.0	OHV Honda	46 x 27 x 24	220
CW-4003-3MGV	4000/276	3.0/11.4	13.0	OHV Vanguard	46 x 27 x 24	220
CW-4004-3MVO	4000/276	4.0/15.1	16.0	OHV Vanguard	46 x 27 x 24	236

Gasoline Belt Drive Features:

- Performance-proven OHV engines with low-oil protection
- Triplex ceramic plunger pump with forged-brass manifold
- Thermal relief valve
- Stainless-steel and brass unloader
- Electric start (includes battery)
- Large removable 11.5 gallon fuel tank for extended run time
- Large capacity bowl-type water strainer
- Positive drive synchronous belt/sprocket system
- Two-piece belt guard with 1/4-turn release for quick access to belt
- Powder coated steel frame with roll cage and lifting hook (patented)
- Solid steel threaded axles
- Pneumatic tires
- Hose wrap with gun/wand holder
- 50-ft. steel wire-braided pressure hose with quick connects and bend restrictors
- Professional-grade trigger gun with safety lock-off
- 48-in. steel lance with rubber grip
- Quick connect nozzles (0, 15, 25, 40 degrees)
- Two-year limited parts and labor warranty
- Five-year pump warranty



CWC-5004-0MGH

Model	PSI/ bar	GPM/ lpm	HP	Engine	Unit Dim. L x W x H (in)	Net. Wt. (lbs)
CWC-4005-0MGH	4000/276	5.0/18.9	20.0	OHV Honda	43 x 27.75 x 36	385
CWC-4005-0MGV	4000/276	5.0/18.9	20.0	OHV Vanguard	43 x 27.75 x 36	385
CWC-5004-0MGH	5000/345	4.0/15.1	20.0	OHV Honda	43 x 27.75 x 36	385
CWC-5004-0MGV	5000/345	4.0/15.1	20.0	OHV Vanguard	43 x 27.75 x 36	385

- continues -

Mi-T-M®

Hot Water HSP Series

Gasoline Direct Drive Features:

- Performance-proven OHV engines with low-oil protection
- Triplex ceramic piston (CAT) pump with forged-brass manifold (1MGH/1MGV)
- Triplex ceramic piston (AR) pump with forged-brass manifold (3MGH/3MGV)
- Over-pressure protection
- Large capacity bowl-type water strainer
- Thermal relief valve
- Stainless-steel and brass unloader
- Built-in low pressure detergent injection
- Exclusive EMF ignition system (patented)
- Energy-efficient top-fired combustion chamber
- Fuel oil, diesel or kerosene fired burner
- Temperature rise 150° maximum
- Whole system diagnostic board
- Easy coil drain
- Wand holder
- Polyethylene burner fuel tank
- Fuel filter/water separator
- Reinforced powder coated steel tube frame with center balanced lifting hook
- Protective coil steel housing
- Solid-steel axles and four pneumatic tires
- 50-ft. steel wire-braided pressure hose with swivel and bend restrictors
- Professional-grade trigger gun with safety lock-off
- Adjustable high/low pressure-insulated dual lance with 15-degree fixed nozzle assembly
- One-year limited parts and labor warranty
- Five-year pump warranty



HSP-2003-3MGV



HSP-3004-1MGH

Model	PSI/ bar	GPM/ lpm	Engine	Burner Tank Cap. gal./L	Unit Dim. L x W x H (in)	Net. Wt. (lbs)
HSP-2003-3MGH	2000/138	2.7/10.2	5.5 HP Honda	4.0/15.1	37 x 29 x 40	266
HSP-2003-3MGV	2000/138	2.7/10.2	6.0 HP Vanguard	4.0/15.1	37 x 29 x 40	271
HSP-2003-1MGH	2000/138	2.7/10.2	5.5 HP Honda	4.0/15.1	37 x 29 x 40	266
HSP-2003-1MGV	2000/138	2.7/10.2	6.0 HP Vanguard	4.0/15.1	37 x 29 x 40	271
HSP-2403-3MGH	2400/166	2.6/9.8	6.5 HP Honda	4.0/15.1	37 x 29 x 40	269
HSP-2403-1MGH	2400/166	2.5/9.5	6.5 HP Honda	4.0/15.1	37 x 29 x 40	269
HSP-3004-3MGH	3000/207	3.5/13.3	11.0 HP Honda	5.5/20.8	43 x 30 x 41	428
HSP-3004-3MGV	3000/207	3.5/13.3	11.0 HP Vanguard	5.5/20.8	43 x 30 x 41	428
HSP-3004-1MGH	3000/207	3.5/13.3	11.0 HP Honda	5.5/20.8	43 x 30 x 41	428
HSP-3004-1MGV	3000/207	3.5/13.3	11.0 HP Vanguard	5.5/20.8	43 x 30 x 41	428
HSP-3504-3MGH	3500/241	3.3/12.5	13.0 HP Honda	5.5/20.8	43 x 30 x 41	428
HSP-3504-3MGV	3500/241	3.3/12.5	13.0 HP Vanguard	5.5/20.8	43 x 30 x 41	430
HSP-3504-1MGH	3500/241	3.3/12.5	13.0 HP Honda	5.5/20.8	43 x 30 x 41	428
HSP-3504-1MGV	3500/241	3.3/12.5	13.0 Vanguard	5.5/20.8	43 x 30 x 41	428

Note: Pump Drive = Direct / EMF Drive = Belt

PRESSURE WASHER ACCESSORIES

Rotating Brush

AW-7003-1500

- Natural hair bristles
- Quick connect
- Adjustable angle
- Rotating action



Rotating Nozzles

- 0° spray with a 25° coverage
- Quick connect nozzle with filter
- Heavy Duty components for long life & reliability

AW-7004-Series*

- 5000 PSI maximum rating

AW-7300-Series*

- 3000 PSI maximum rating

AW-7500-Series*

- 5000 PSI maximum rating

*Call for correct orifice size



Low Pressure Detergent Injector

AW-8300-0000

- Adjustable flow valve
- Clear, pliable detergent hose with large stainer
- Solid brass detergent nozzle
- Quick connect coupler



High Pressure Detergent Injector

50-0161

- Brass and stainless steel construction
- Adjustable metering valve
- Steel mesh in-line water strainer
- Operating capacity of 6 GPM



Sand Injector

AW-3000-0000

AW-3020-0000

- Includes sand probe and clear hose
- Consult factory before ordering



Extension Reach Wand

AW-7015-1200 (12 foot)

AW-7015-1800 (18 foot)

AW-7015-2400 (24 foot)

- Professional grade trigger gun with safety lock-off
- Complete with quick connect



Extension Hose

851-0006 (4000 PSI)

851-0007 (3000 PSI)

- 50' x 3/8" I.D.
- High pressure hoses include bend restrictors, swivel and quick connects



Rollcage

CX-0053 9 HP GAS

CX-0054 11 & 13 HP GAS

CX-0055 16 HP GAS

CX-0056 9 HP YANMAR



Equipment

Skidmore-Wilhelm

Skidmore-Wilhelm

TORQUE-TENSION TESTERS

- Reduce fastener costs
- Establish assembly standards
- Assure consistent power tool output
- Control product quality

How Exactly Do You Use a Skidmore-Wilhelm Torque-Tension Tester?

Determine the exact torque-tension relationship to establish tightening standards for each applications.

The tester lets you easily determine the joint torque-tension relationship. First, insert the fastener into the tester. Then, tightening the nut creates pressure, which is transmitted to the gage through hydraulic fluid. the gage is calibrated to read directly in pounds tension.

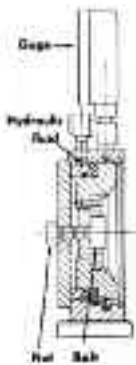

As you tighten the fastener with a hand torque wrench, the tester gage registers tension and the torque wrench registers torque. noting both readings at a specified point establishes the torque-tension standard for the joint.

Test power Tool output under Standard Conditions with precision test Bolt assemblies.

On a day-to-day basis, how do you know your power tools are delivering consistent tightening force each time you use them? Easy.

With a Skidmore-Wilhelm Torque-Tension Tester, you calibrate each tool individually and keep a record of its out-put performance. Then periodically - even every day - check the tool against its established norm. Any deviation in output signals the need for adjustment or maintenance *before it affects product quality.*

Consistent, accurate power tool output testing requires standard, repeatable test conditions. Most importantly, test conditions should simulate as closely as possible the way the tool is actually used on the job.

Production fasteners are poorly suited for test purposes and should not be used. They are subject to many variations, and physical changes from repeated tightening and retightening can adversely affect the torque-tension relationship.

To avoid such problems and guarantee standard power tool test conditions, Skidmore-Wilhelm makes special hardened ally steel test bolt assemblies. first use the appropriate-sized assembly to establish a tool's performance norm. Then each time you retest the tool simply use the same test bolt assembly and compare the output.

Test Bolt Assembly



Use Skidmore-Wilhelm Torque-Tension Testers to Choose the Right Fasteners and Consistently Tighten Them to Specifications.

Check fastener strength: During design, your Skidmore-Wilhelm Torque-Tension Tester lets you perform torque-to-yield tests and torque-to-failure tests to determine the right fastener: not simply the strongest fastener, but the least expensive fastener strong enough to secure the joint. You can spot check fastener quality at any time. And because you can place actual joint component samples in the tester, you can study how plating, types of washers, lubrication, and other joint variables affect the amount of torque needed to produce the required tension. In this way the tester lets you establish accurate torque-tension tightening standards.

Check power tool performance: Our testers let you determine the output of all kinds of power tools - pneumatic, electric, and hydraulic impact wrenches, and nutrunners. You can verify settings for adjustable output power tools, periodically check output against established norms, and ensure that assembly personnel are using power tools consistently. Tool crib personnel or maintenance foremen: you can quickly verify the performance of new and rebuilt power tools as well as test whether older tools need maintenance. And because you test your power tools by actually using them in a tightening situation, you closely simulate the tool's on-the-job operating conditions. *Skidmore-Wilhelm Torque-Tension testers ensure quality consistency and control.*

Torque-Tension Testers for Small, Medium, and Large Application

Torque-Tension Tester models are designed according to fastener size and type, maximum pre-load, and, for power tool output testing, the drive size of the power tool. Special test bolt assemblies for power tool testing are available for all models. If desired, any model can be ordered with a dual-reading gage that indicates tension in metric units as well as pounds.



Large Applications:

- **Fastener:** Bolts 1-1/4" through 2-1/2" (M32-M64)
- **Tension capacity:** 225,000 Lbs. maximum
- **Tool/size:** 1" to 2-1/2" square drive
- **Test bolt assembly:** 6 sizes available: 1-1/4" - 2-1/2"

Medium Applications

- **Fastener:** High-strength bolts 1*1/8" through 1-1/2" (M30-M38)
- **Tension capacity:** 170,000 Lbs. maximum
- **Tool/size:** 3/4" - 1-3/4" square drive
- **Test bolt assembly:** 3 sizes available: 1", 1-1/4", 1-1/2"



- **Fastener:** Bolts 5/8" through 1-1/4" (M16-M32)
- **Tension capacity:** 100,000 Lbs. maximum
- **Tool/size:** 1/2" through 1-1/2" square drive
- **Test bolt assembly:** 3 sizes available: 3/4", 1", 1-1/4"



- **Fastener:** Screws and bolts #10 through 9/16" (M5-M16)
- **Tension capacity:** 30,000 Lbs. maximum
- **Tool/size:** 1/4" through 3/4" square drive
- **Test bolt assembly:** 2 sizes available: 5/8", 7/8"

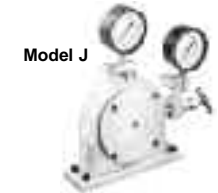

Model J features a separate low-range gage for easy reading over the tester's entire operating range.

Small Applications

- **Fastener:** Machine screws #6, #8, #10, and 1/4" (M3-M6)
- **Tension capacity:** 5,000 Lbs. maximum
- **Tool/size:** Power screwdrivers and small impact wrenches

Model S can be bench-mounted vertically or horizontally. Ideal for testing small fasteners.



Adapter Sets

Each Skidmore-Wilhelm Torque-tension Tester comes complete with plate and bushing adapters that allow you to test a variety of hex head bolts and cap screws. Self-tapping screws can also be tested. For shorter length bolts, tapped bushings are available. Have an unusual head configuration? Skidmore-Wilhelm can make up special adapters. Need metric? Adapter sets are also available in metric. Adapter sets are also available in metric equivalent sizes. See the accompanying chart to determine which adapter sets come standard with each tester model.



TESTER MODEL	STANDARD ADAPTERS FURNISHED FOR USE WITH THE FOLLOWING:
Model S	#6, #8, #10, & 1/4" fasteners
Model J	#10, 1/4", 5/16", 3/8", 7/16", 1/2" & 9/16" fasteners
Model RL	5/8", 3/4", 7/8", 1", 1-1/8", 1-1/4" fasteners
Model H	1-1/8" through 1-1/2"
Model K	1-1/4" through 2-1/2" fasteners

Skidmore-Wilhelm/Scotchman

Test Bolt Assemblies

Choose test bolt assemblies from the accompanying table based on power tool square drive size, tester model and hex socket size.



TENSION-TESTER MODEL	BOLT ASSEMBLY PART NO.	TEST BOLT SIZE (in)	POWER TOOL SQ. DR. (in)	HEX SOCKET	MAX NORM
S	S-105	5/16	1/4	3/8	5,000
J	J-110	5/8	3/8, 1/2, 5/8	9/16	15,000
J	J-114	7/8	5/8, 3/4	7/8	30,000
M, ML, RL	R-112	3/4	5/8, 3/4	1-1/4	30,000
M, ML, RL	R-116	1	3/4, 1	1-5/8	70,000
M, L, RL	R120	1-1/4	1, 1-1/4	2	110,000
H	H-116	1	3/4, 1	1-5/8	70,000
H	H-120	1-1/4	1, 1-1/4	2	110,000
H	H-124	1-1/2	1-1/4, 1-1/2	2-3/8	170,000
K	K-120	1-1/4	1, 1-1/4	2	110,000
K	K-124	1-1/2	1-1/4, 1-1/2	2-3/8	170,000
K	K-128	1-3/4	1-1/2, 1-3/4	2-3/4	225,000
K	K-132	2	1-3/4, 2	3-1/8	225,000
K	K-136	2-1/4	2, 2-1/4	3-1/2	225,000
K	K-140	2-1/2	2-1/4, 2-1/2	3-7/8	225,000

Other Fastener/Tool Testing Products and Services

The complete Skidmore-Wilhelm product line covers a range of fastener and assembly tool testing products for both industrial and construction applications. Descriptive bulletins are available giving detailed information on most Skidmore-Wilhelm products.

Model M Bolt Tension Calibrator

Clamps directly to beam or column for on-site calibration of impact wrenches used to tighten high-strength bolts on structural steel. Also tests fastener strength. Accepts bolt diameters 1/2" to 1-1/4", 100,000 Lbs. maximum preload. Ideal for construction-site fastener testing. Ask for construction-site fastener testing. Ask for Bulletin 110.

Model MS Bolt Tension Calibrator

Same functions as Model M, but designed specifically for shorter-length construction bolts, including Tension-control bolts, 1/2" to 1" in diameter. 90,000 Lbs. capacity. Bulletin 112.

Model P 3/8" Bolt Tension Tester

For sales demonstrations showing comparative fastener strength. Easily clamps to a customer's desk or a bench. Ask for Bulletin 101.

Model W Torque Wrench Calibrator

For setting and checking beam, dial reading, or micrometer torque wrenches. Ask for Bulletin 210.

Model PT Digital Torque Tester

For checking performance of impact wrenches and hand torque wrenches. Patented electronic design gives direct digital readout of torque in foot-pounds or newton-meters. Ask for Bulletin 510.

ACCESSORIES:

Model LR-100 Hydraulic Load Reliever

A hydraulic hand pump that attaches to a tester by means of a quick-disconnect fitting. Simulates service conditions by adding additional load to a bolt already preloaded in the tester. Also, by relieving the pressure on a bolt/lock nut assembly, the LR-100 allows measurement of the torque required to back off a prevailing torque lock nut - without loosening the nut.



Air Timer Control

Foot switch operated air timer control delivers air to power tool at a set pressure for a fixed time interval. Electric timer actuates a solenoid valve that shuts off air flow after a pre-set interval. Ensures that the true efficiency of the tool is the only test variable. Operates on either 110 or 220 volts; connects to existing 3/8" or 3/4" air lines.

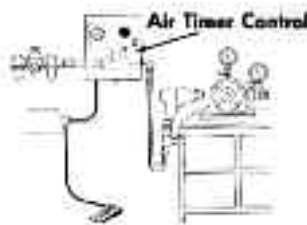

Ironworker

Model 6509-24M

Standard Features

- Punching Capacity 65 Tons
- 9" Throat Depth
- Angle Shear Capacity 6" x 6" x 3/8" and 5" x 5" x 1/2"
- Bar Shear Capacity 24". Blades Complete with 4 Cutting Edges
- Tool Table Work Area for Mounting Optional Tooling
- Die Holder Complete with 2" Die Insert
- Remote Foot Pedal
- Adjustable Stripper
- Adjustable Stroke Control with Scale
- Two Stage Pump
- Jam Nut with Wrench
- Electrical Box Supplied with Emergency Palm Button and Lock-out Tag-out Accommodations
- 230/460 Volt 3 Phase Electrics
- All Guards Necessary to Comply with ANSI B 11-5 Standards
- Fork Lift Accommodations
- 1-Year Warranty



Capacities & Specifications Rated on 65,000 PSI Tensile A Mild Steel:

Throat Depth	9"	Rod Shear	10 Cavities
Punching Cap.	65 Tons	Round	1/4" to 1-1/4"
	1-1/16" IN 3/4"	Square	1/4" to 1"
Special Tooling	4" IN 3/16"	90 V. Notcher	6" x 6" x 5/16"
Flat Bar Shear	24" Length	Rectangle Notcher	2" x 2-1/2" x 3/8"
	1" x 6"	Pipe Notching	3/4", 1"
	3/4" x 8"	Schedule 40 I.D.	1-1/4", 1-1/2" or 2"
	3/16" x 24"	Brake 12"	40 Ton
Opt. Saber Blade	1/2" x 16"	18"	35 Ton
	3/8" x 24"	24"	30 Ton
Angle Shear 90	6" x 6" x 3/8"	Hydraulics	2,500 PSI
Angle Shear 45	4" x 4" x 1/2"	Motors	
Strokes Per Min.		Standard	230/460/5HP 3PH
Lt. Material	40		200/208/340/380
Max. Capacity	12		400/415/550/575
Channel Shear	2" to 5" Adj.	Optional	230 5HP 1PH
Pickett tool	1/2", 3/4" & 1"	Dimensions	W-24" L-60" H-66"
		Weight	2,750 Lbs.

Note: Six foot back gauge, oversized Punch Table and oversized Shear Table are also available, please call for more information.

Ironworker

Model 9012-24M

Standard Features

- Punching Capacity 90 Tons
- 12" Throat Depth
- Angle Shear Capacity 6" x 6" x 1/2"
- Bar Shear Capacity 24". Blades Complete with 4 Cutting Edges
- Tool Table Work Area for Mounting Optional Tooling
- Die Holder Complete with 2" Die Insert
- Adjustable Stripper
- Jam Nut with Wrench
- Removable Foot Pedal
- Adjustable Stroke Control with Scale
- Two Stage Pump
- Electrical Box Supplied with Emergency Palm Button and Lock-out Tag-out Accommodations
- 230/460 Volt 3 Phase Electrics
- All Guards Necessary to Comply with ANSI B 11-5 Standards
- Fork Lift Accommodations
- 1-Year Warranty



- continues -

Equipment

Scotchman/Stone®

Ironworker (Model 9012-24M) – continued

Capacities & Specifications Rated on 65,000 PSI Tensile A 36 Mild Steel:

Throat Depth	12"	Rod Shear	10 Cavities
Punching Cap.	90 Tons 1-1/16" IN 1"	Round	1/4" to 1-1/4"
Special Tooling	4" Max. Dia.	Square	1/4" to 1"
Flat Bar Shear	24" Length 1" x 8" 3/4" x 10" 1/2" x 16" 1/4" x 24"	90 V. Notcher	6" x 6" x 5/16"
Opt. Saber Blade	1/2" x 22" 3/8" x 24"	Rectangle Notcher	2" x 2-1/2" x 3/8"
Angle Shear 90	6" x 6" x 1/2"	Pipe Notching	3/4", 1" Schedule 40 I.D. 1-1/4", 1-1/2" or 2"
Angle Shear 45	4" x 4" x 1/2"	Brake 12"	50 Ton
Strokes Per Min.	37	18"	45 Ton
Lt. Material		24"	40 Ton
Max. Capacity	10	Hydraulics	2,500 PSI
Channel Shear	2" to 6" Adj.	Motors	
Picket tool	1/2", 3/4" & 1"	Standard	230/460/5HP 3PH 200/208/340/380 400/415/550/575
		Optional	230 5 HP 1 PH
		Dimensions	W-26" L-76" H-70"
		Weight	3,900 Lbs.

Note: Six foot back gauge, oversized Punch Table and oversized Shear Table are also available, please call for more information.

CPO 350 Series

- American Made
- Double self-centering vise assures burr-free cuts
- Miter capabilities 180° left and right
- Miter locking device stops at 45° left, straight 90° and 45° right
- Double reduction gear box. Both gears are hardened and ground
- Worm wheel of top quality bronze
- Slotting and longitude cutting
- Material length stop 30"
- 1 HSS Blade 12-1/2" diameter
- 2 cutting speeds
- 10 gallon coolant tank with pump
- 1 gallon coolant
- 1 blade wrench
- Completely assembled ready for operation
- Warranty: 1 year parts

CPO 350 Manual Saw

- Manual Clamp for Material Vise
- Operator control Trigger Switch

CPO 350 PK Manual Saw

- Air Operated Power Clamp for Material Vise
- Operator Control Trigger Switch

CPO 350 PKPD Semi-Automatic Saw

- Air Operated Power Clamp for Material Vise
- Pneumatic Operated Power Down Feed
- Emergency Stop Button



CPO 350

Maximum Capacities		
Tube	90 Degree	45 Degree
Round	4-7/8"	4-3/8"
Square	4-3/8" x 4-3/8"	4" x 4"
Rectangle	5-1/2" x 4"	4" x 4"
Solid	90 Degree	45 Degree
Round	2"	1-3/4"
Square	2" x 2"	1-3/4" x 1-3/4"

Specifications:

- Cutting Speeds - must specify when ordering
- LT (Low Turns) designed for solid mild steel, solid stainless steel & tick wall pipe

LT 22/44 RPM	Motor Rate: Low RPM 1 HP - High RPM 2 HP
LT Variable Speed Drive 11 to 88 RPM	Motor Rate: Low RPM 1 HP - High RPM 2 HP
- HT (High Turns) designed for thin wall tube and non-ferrous material

HT 44/88 RPM	Motor Rate: Low RPM 2 HP - High RPM 2.7 HP
HT Variable Speed Drive 22 to 176 RPM	Motor Rate: Low RPM 2 HP - High RPM 2.7 HP

- Factory wired. Specify 230 PH, 460 3 PH or 575 volt 3 PH 60 Hz
- Maximum diameter Blade: 14"
- Arbor Bore: 1-9/16"
- Pin Spacing: 4/12/64 & 2/8/55
- Width: 21-7/8"
- Depth: 17-1/2"
- Height not. incl. handle: 56-1/4"
- Height floor to vise: 37-7/16"
- Shipping Wt: 675 lbs.

Stone®

Mortar Mixers

Stone Mortar, Plaster and Fireproofing mixers fit every mixing need. From a small wheelbarrow style to a heavy-duty totally enclosed gear drive mixer, Stone offers more models, more available engine options and more standard features than any other brand.

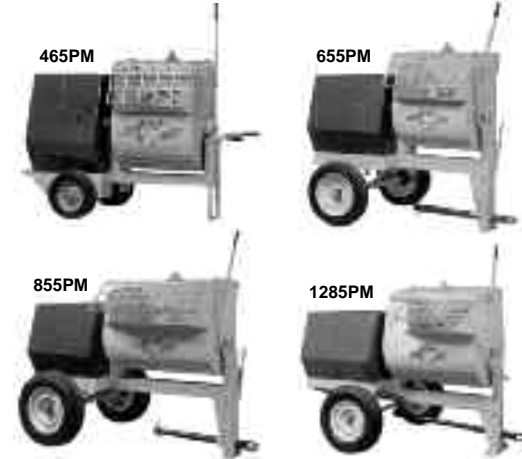

Model	465PM	655PM	855PM/ 855PMP*	1285PM
Batch Cap* Bags	3/4 - 1	1-1/2 - 2	2-1/2 - 3	3 - 4
Batch Cap* Ft³	4	6	8	12
Total Vol.* Ft³	4.3	6.9	9.0	14.8
Ship. Dim. (L x W x H)	58 x 29 x 37	64 x 34 x 54	76 x 34 x 54	81 x 56 x 59
Drive & Clutch	V-belt to Gears Hand clutch at side	V-belts to Gears Front Post Hand Clutch	V-belts to Gears Front Post Hand Clutch	Totally Enclosed Gear Drive & Clutch (no chain or belt)
Power Options	w/o power 5 hp B&S 5.5 hp Honda 3/4 hp Electric 1 hp Electric	w/o power 5 hp B&S 5.5 hp Honda 8 hp B&S 8 hp B&S I/P** 8 hp Honda 7.5 hp Robin 6 hp Robin 1-1/2 hp Electric	w/o power 8 hp B&S 8 hp B&S I/P** 11 hp B&S I/P 8 hp Honda 7.5 hp Robin 2 hp Electric	9.2 hp Wisconsin 11 hp Honda 18 hp B&S I/C 5 hp Electric 11 hp Robin
Std. Wheels, Bearings & Axle	3.00 x 12 (12" dia.) semi-pneumatic tires Sleeve Bearings 3/4" dia. Fixed Axle	4.80 x 12 (20" dia) high speed tires Tapered Roller Bearings Extendible Axle (34" to 46") Safety Chain	B78 x 13 (25" dia) high speed tires Tapered Roller Bearings Extendible Axle (34" to 46") Safety Chain *Poly Drum	B78 x 13 (25" dia) high speed tires Tapered Roller Bearings 56" Axle/ Cantilever Springs Safety chain
Wt. (lbs)	276# w/5 B&S	550# w/8 B&S	605# w/8 B&S	1120# w/9.2 Wisc.

* Batch capacity varies, based on ratio of materials used. Batch size will never equal total volume.

** Low oil guard shutoff

Optional spiral blades available on 655PM & 855PM

Concrete Mixers

Stone concrete mixers meet every job site application and include the largest portable concrete mixing capacities in the industry.



– continues –

TPI Corp.

TPI Corp.

INDUSTRIAL FANS

Heavy Duty Air Circulator

- **Size:** 24" & 30"
- **Motor:** 2-speed, 1/2 HP, 1 Ph., 115V ball bearing, totally enclosed permanently lubricated permanent split capacitor.
- **Switch:** Pull Chain
- **Cord:** SJT type 3 conductor, 18' long
- **Guards:** Powder coated steel
- **Blade:** Steel hub/spider aluminum paddles
- Adjustable column (4-1/2' to 7') bolts to 27" diameter steel dome base with 5 carriage bolts.
- Safety yellow powder coated motor, oversized guards and mounts.
- Factory assembled and tested fan head (motor-blade-guard) shipped in one carton with mount in a separate carton.



HDH-30 Fan Head w/HDM-P Mount

Meets OSHA Standards - U.L. Listed - 5 Year Limited Warranty

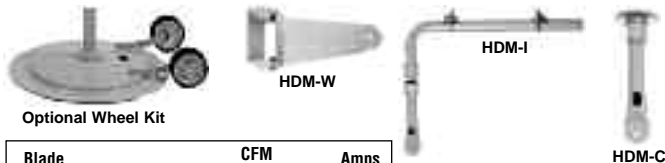

Optional Wheel Kit

Blade Size (in)	Fan Head	CFM		Amps (High)
		High	Low	
24	HDH 24	8600	6500	5.4
30	HDH 30	9850	7500	5.6

Size (in)	Fan Type	Style Number	Model No.		Ship. Wt. (lbs)
			Fan Head	Mount	
24	Fan Head		HDH 24	-	44
	Pedestal Fan	HD 24-P	HDH 24	HDM-P	78
	Wall Mount Fan	HD 24-W	HDH 24	HDM-W	47
	I-Beam Mount Fan	HD 24-I	HDH 24	HDM-I	53
	Ceiling Mount Fan	HD 24-C	HDH 24	HDM-C	47
30	Fan Head		HDH 30	-	48
	Pedestal Fan	HD 30-P	HDH 30	HDM-P	82
	Wall Mount Fan	HD 30-W	HDH 30	HDM-W	51
	I-Beam Mount Fan	HD 30-I	HDH 30	HDM-I	57
	Ceiling Mount Fan	HD 30-C	HDH 30	HDM-C	51
Optional Wheel Kit				HD-WK	2

Direct Drive Portable Blower

- **Size:** 36" & 42"
- **Motor:** 2-speed on 36" model/1 speed on 42" model, Single Phase, 115 Volt, ball bearing, permanently lubricated, 1050 rpm, totally enclosed, PSC type
- **Switch:** Rocker
- **Cord:** SJT type 3 conductor, 15' long
- **Blade:** 3 paddle steel
- **Guards:** Spiral wire - front and rear
- Powder coated 20 ga. steel housing has front and rear roll formed embossments for added strength and rigidity.
- Swivel model rotates 360° in 12-1/2° increments and locks in place with a steel locking pin.
- 8" Rubber Wheels

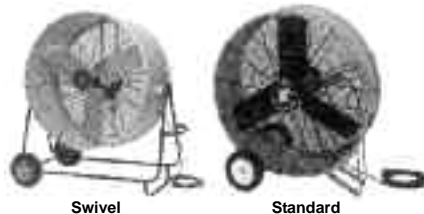

Swivel

Standard

Meets OSHA Standards - U.L. Listed - 1 Year Limited Warranty

Blade Size (in)	Fan Type	Motor HP	Model No.	CFM High	CFM Low	AMPS (high)	Ship. Wt. (lbs)
36	Standard	1/3	PB 36-D	12500	9000	5.6	82
36	Swivel	1/3	PBS 36-D	12500	9000	5.6	110
42	Standard	1/2	PB 42-D	15,600		7.9	102
42	Swivel	1/2	PBS 42-D	15,600		7.9	128

Work Station Fan

- **Size:** 12" & 18"
- **Motor:** 3-speed, 1 Ph., 115V Sleeve bearing Permanently lubricated
- **Switch:** Pull chain
- **Cord:** SJT type 3 conductor, 10' long
- **Blade:** Aluminum
- **Guards:** Double locking chrome plated
- Totally enclosed motor.
- Mount with one bolt or lag screw to walls, ceilings, workbenches, machines or any surface.
- Fan head rotates 360° in both the horizontal and vertical direction.



Meets OSHA Standards - U.L. Listed - 1 Year Limited Warranty

Size (in)	Model No.	Motor HP	CFM			Amps High	Ship Wt. (lbs)
			High	Med	Low		
12	U-12-TE	1/12	2750	2200	1600	1.1	13
18	U-18-TE	1/8	5750	4700	3200	2.2	20



Industrial Floor Fan

- Totally Enclosed Motor
- **Size:** 12" & 18"
- **Motor:** 3-speed, 1 Ph., 115V Sleeve bearing Permanently lubricated
- **Switch:** Rotary
- **Cord:** SJT type 3 conductor, 10' long
- **Head Tilt:** 360°
- **Guards:** Double locking chrome plated
- **Blade:** Steel hub/spider aluminum paddles



F12-TE
F18-TE

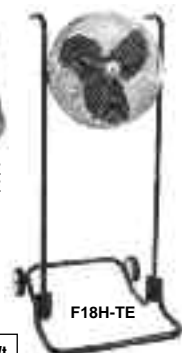

Overall height of F18H-TE is 53".

Meets OSHA Standards - U.L. Listed - 1 Year Limited Warranty

Size (in)	Model No.	Motor HP	CFM			Amps High	Ship. Wt. (lbs)
			High	Med	Low		
12	F-12-TE	1/12	2750	2200	1600	1.1	13
18	F-18-TE	1/8	5750	4700	3200	2.2	20
18	F-18H-TE	1/8	5750	4700	3200	2.2	27

Office Oscillating Fans

- 3-speed oscillating fans with push button controls
 - 3 conductor SPT cord & plug
 - White powder coated wire mesh guards
 - White plastic housing & blade
 - Stand fan extends to 40" height
- Meets OSHA Standards - U.L. Listed - 1 Year Limited Warranty



Desk Fan



Stand Fan

Size (in)	Model No.	Fan Type	Speeds	CFM High	Amps High	Ship. Wt. (lbs)
12	ODF-12	Desk	3	1200	.4	5.4
16	ODF-16	Desk	3	2100	.5	8.5
16	OSF-16	Stand	3	2100	.5	15.5

Equipment

TPI Corp.

Industrial Ceiling Fans

- All metal construction
- 18 Pole, 115 V, 1 Ph. Capacitor type, impedance protected motor with sealed ball bearings
- Mounts to 3/8" diameter steel J-hook
- White epoxy finish
- Aluminum paddles
- 18" Down rod standard, 24" or 36" down rods available
- UL Listed



Commercial Grade

- Assembly required
- 18" lead wires
- 1 Year Warranty
- Safety cable included

Industrial Grade

- Fully assembled except blade bolt down
- 3 Conductor cord, 4' long with plug
- Moisture/Dust resistant construction available as "DR option"
- 3 Year Warranty
- Safety cable included

Heavy Duty Grade

- Fully assembled except blade bolt down
- 3 Conductor cord, 6' long with plug
- Moisture/Dust resistant construction available as "DR option"
- 6 Year Warranty
- Safety cable included

Grade	Model	Type	Size (in)	CFM	RPM	AMPS	Ship Wt. (lbs)
Commercial	CHR-56	Down Draft	56	19000	320	1.0	19
Industrial	IHR-48	Down Draft	48	17000	320	.7	20
Industrial	IHR-56	Down Draft	56	21000	310	.9	21
Industrial	IHR-56R	Reversible	56	21000	310	.9	21
Industrial	IHR-56-277V*	Down Draft	56	21000	310	.6	21
Heavy Duty	HDHR-56	Down Draft	56	27500	320	1.1	17
Heavy Duty	HDHR-60	Down Draft	60	47000	320	1.1	18

*277 volts - lead wires instead of cordset

Solid State Controls		
Model	Type	Amps
HR-SS-2	1-2 Fans Speed Control	3 Max.
HR-SS-5	3-5 Fans Speed Control	6 Max.
HR-SS-10	6-10 Fans Speed Control	12 Max.
HR-SS-5R	1-5 Fans Reversing Switch	6 Max.

Options	
Model	Type
HR-Guard	Wire Safety Guard for 56" Models
Suffix - X2	24" Down Rod Option
Suffix - X3	36" Down Rod Option

Fan Forced Milkhouse Heater

Model	188TASA
Type	Fan Forced
Volts/Phase	120 Volts 1 Phase
Watts	1500/1300/Fan Only
Max BTU's Per Hour	5120
Cordset	6' Long 3 Conductor
Temp Control Thermostat	Yes
Safety System	Tip Switch & Over Heat Limit Protection with Audible Alarm
Shipping Weight	9 Lbs.
Width: 10" Height: 16" Depth: 9-1/2"	



Ceramic Fan Forced Portable Heater

Model	178 TMC
Watts	1500/950
MAX BTUs	5120
Volts	120
AMPS	12.5/7.1
Phase	1
Shipping Weight	8 Lbs



Combination Radiant & Fan Forced Heater

Model	198 TMC
Type	Radiant and Fan Forced
Volts/Phase	120 Volts 1 Phase
Watts	1500/900/600
Max BTU's Per Hour	5120
Cordset	6' Long 3 Conductor
Temp Control Thermostat	Yes
Safety System	Tip Switch & Over Heat Thermostat
Shipping Weight	9 Lbs.
Width: 11" Height: 15" Depth: 12"	



Portable Electric Salamander

- Safety yellow heater enclosure with safety screens on both air intake and output openings.
- Optional 25' long SO type cord, ready for plug attachment is available for each model.
- Long-life finned tubular heating elements.
- Thermostat adjustment 40° to 100° F.
- Magnetic contactor.
- High-limit thermal cutout switch. / Automatic reset.
- 10" wheels.
- 800 CFM: 9, 10, & 15KW units -
- 1100 CFM-30KW units.
- Made in U.S.A.



Model No.	KW	BTU	Volts	Phase	AMP	CFM	Temp. Rise	Ship Wt. (lbs)
FES-1520-3A	15	51195	208	3	42	800	45	65
FES-1524-1A	15	51195	240	1	63	800	45	69
FES-1524-3E	15	51195	240	3	36	800	45	65
FES-1548-3E	15	51195	480	3	18	800	45	65
FES-1560-3A	15	51195	600	3	15	800	45	65
FES-3048-3A	30	102390	480	3	36	800	90	83
FES-3060-3A	30	102390	600	3	29	800	90	65

Portable Infrared Heaters

- High density medium wave radiant heat with 60° symmetrical heat pattern.
- 25,000 hour element life expectancy
- Approximately, 78.5% efficient versus 50% for metal sheath type elements.
- Rugged flat panel emitter can be used in high vibration areas
- Single or three phase available on select models
- Heavy duty wire guard mounted on long lasting gold anodized reflector
- Made in U.S.A.



Model No.	Watts	Volts	Phase	BTUs/Hr.	AMPS		Wt. (Lbs)
					1ph	3ph	
FSP-3120-1	3150	208	1	10,749	15.4	NA	23
FSP-3124-1	3150	240	1	10,749	13.13	NA	23
FSP-3127-1	3150	277	1	10,749	11.37	NA	23
FSP-3148-1	3150	480	1	10,749	6.56	NA	23
FSP-3157-1	3150	600	1	10,749	6.48	NA	23
FSP-4320-3	4300	208	1 or 3	14,972	20.67	11.94	32
FSP-4324-3	4300	240	1 or 3	14,972	17.91	10.36	32
FSP-4327-1	4300	277	1	14,972	15.52	NA	32
FSP-4348-3	4300	480	1 or 3	14,972	8.96	5.18	32
FSP-4357-3	4300	600	1 or 3	14,972	7.48	7.48	32
FSP-9520-3	9500	208	1 or 3	32,414	45.67	26.39	46
FSP-9524-3	9500	240	1 or 3	32,414	39.68	22.89	46
FSP-9527-1	9500	277	1	32,414	34.3	NA	46
FSP-9548-3	9500	480	1 or 3	32,414	19.79	11.44	46
FSP-9557-3	9500	600	1 or 3	32,414	16.52	9.54	46

* Includes 15' cordset w/grounded plug.

TPI Corp.

Heavy Duty Machine Tool Lights

Incandescent

- Patented disc and collar swivel joints.
- Horizontal or vertical bolt down mounting bracket.
- Arms made of 5/8" steel tubing.
- Replaceable 10 amp rocket switch.
- Replaceable glazed porcelain lamp socket.
- 8' 18/3 SJTO-Cord set (total length) with molded grounded plug.
- Charcoal gray baked-on enamel finish.
- Bar knobs and collar thumbscrews eliminate need for hand tool for adjustable fixture.
- For units without switch - consult factory.
- Lamps not included.

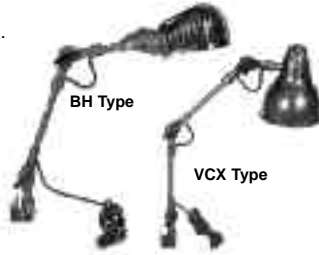

Model	Lamps	Over-All Reach (in)	Footcandles 12" From Light			Ship. Wt. (lbs)
			Center	+10"	+20"	
5-BH-701A	60 Watt medium base A-1-23 or smaller	25	290	145-155	60-75	5
55-BH-701A	60 Watt medium base A-1-23 or smaller	35	290	145-155	60-75	5
66-BH-701A	60 Watt medium base A-1-23 or smaller	44	290	145-155	60-75	5
55VCX-701B	100 Watt medium base A-19-23, or R-30, PAR-38 Reflector lamp, or PAR-38 Halogen reflector lamp	29	475	270-350	95-150	5
66-VCX-701B	100 Watt medium base A-19-23, or R-30, PAR-38 Reflector lamp, or PAR-38 Halogen reflector lamp	38	475	270-350	95-150	6
Optional 35-710 Base Clamp-On Attachment						1

High Pressure Sodium

50W H.P.S. Lamp produces twice the light as 100W incandescent bulb, but uses 1/2 the energy and lasts 32 times longer (24,000 hours).

Fluorescent

Two instant start fluorescent tubes produce 1/3 the heat of a 100W incandescent bulb and lasts 13 times longer (10,000 hours).

- Patented disc and collar swivel joints.
- Horizontal or vertical bolt down mounting bracket.
- Arms made of 5/8" steel tubing.
- 8' 18/3 SJTO-Cord set (total length) with molded grounded plug.
- Charcoal gray baked-on enamel finish.
- Bar knobs and collar thumbscrews eliminate need for hand tool for adjustable fixture.
- Lamps not included.



Model	Lamps	Over-All Reach (in)	Footcandles 12" From Light			Ship. Wt. (lbs)
			Center	+10"	+20"	
55-HPS-029A	50 Watt High Pressure Sodium (no bulb)	35	400	380-390	360-375	10
HPS-B	50 Watt H.P.S. bulb					1
66-FTT26-201B	Includes two 13 Watt instant start fluorescent tubes	38	340	255	125	8
Optional 35-710 clamp-on base attachment for model 66-FTT26-201B						1

Specialty Work Lights

- Optional beige or brown color.
- Spring activated arm with 25"/33"/45" reach.
- Clamp-on or bolt-on base - clamps to a flat surface up to 2" thick.
- 3-wire, grounded, 8' cord set with molded plug.
- On/off rocker switch.
- Convenience outlet - can be used to power a small appliance or a series of lights, totaling up to 5 amps.
- 3 diopter lens (1.75 times magnification at 13" focal length) standard.
- 5 diopter lens (2.25 times magnification at 3.75 inches) available on 45" unit. (/5X)
- A 22W T-9 circline fluorescent lamp included.



Flourescent Magnifiers

Model Number	Reach (in)	Ship Wt. (lbs)
MAG-S25-CO	25	9
MAG-S33-CO	33	9
MAG-S45-CO	45	9
MAG-S45-CO/5X	45	9

Heavy Duty Dock Lights

Incandescent • High Pressure Sodium • Quartz Halogen

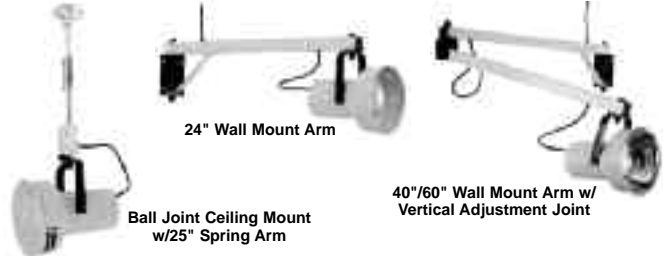

	Light Selection Chart		
	Incan- descent	High Pressure Sodium	Quartz Halogen
Wattage	150W	50W	500W
Lumens	2000	4000	11000
Average bulb life (hr)	2000	24000	2000
On/Off Switch	Yes	Yes	No
Bulb included	No	Yes	No

Wall Mount Arm

- Yellow powder coated, 14 gauge steel tubing.
- On dual arm units, outer arm swings 300° in horizontal plane and 210° in vertical plane.
- 4' of 18/3 SJT cord (no plug) available for wiring to customer supplied electrical box.
- 3" x 5" x 3/16" steel mounting plate accepts 3/8" hardware.

Type	Incandescent		High Pressure Sodium		Quartz Halogen	
	Model No.	Ship Wt. (lbs)	Model No.	Ship Wt. (lbs)	Model No.	Ship Wt. (Lbs)
25" Ceiling Mount	DK-25 SA	8	DK-25 SA/HPS	9	DKQH-25 SA	11
24" Wall Mount	DK-24	11	DK-24/HPS	12	DKQH-24	15
40" Wall Mount	DK-40-VA	15	DK-40 VA/HPS	18	DKQH-40 VA	18
60" Wall Mount	DK-60 VA	18	DK-60 VA/HPS	19	DKQH-60 VA	22
Replacement bulb			HPS-B		QH-B	

Equipment

Universal

Universal

Estimating the space to be heated:

The following formula is used to determine the BTU's needed to heat a building. This calculation would be for an average uninsulated building. Add more BTU's if the building will have a great deal of heat loss open windows and weather doors and reduce the BTU's if the building is well insulated and weather tight.

$$\boxed{\text{CUBIC FEET TO BE HEATED}} \times \boxed{.133} \times \boxed{\text{DESIRED TEMPERATURE RISE}} = \boxed{\text{BTU'S/HOUR}}$$

- **CUBIC FEET TO BE HEATED-** Multiply the length times the width times the height of the area to be heated
- **DESIRED TEMPERATURE RISE-** Subtract the lowest expected outside temperature from the desired inside temperature

EXAMPLE:

A concrete block building 50 feet wide by 200 feet long with 20 feet from the floor to the ceiling.
All window and door openings are temporarily covered with plastic.
The outside temperature is 15 degrees and we want the inside temperature to be 55 degrees.

Cubic Feet = 50 x 200 x 20= 200,000 cubic feet

Temperature Rise = 55 - 15 = 40 degrees

BTU's Needed: 200,000 x .133 x 40 = 1,064,000 BTU's per hour

Heaters Needed: Four 250,000 BTU Convection Heaters or Three 375,000 BTU Forced Air heaters will heat this job.

ALWAYS VENTILATE THE HEATING AREA

PROPANE & NATURAL GAS FORCED AIR

Model 30-FAS

(30,000 BTU/HR) Blower Type Forced Air Heater

Ideal for shops, work areas, farm, ranch and craftsmen. Features push button electronic ignition, stainless steel burner, high performance squirrel cage blower. Compact box design heats up to 5,000 cu.ft. of space. Ignition will not take place unless heater is plugged in. Propane flow stops if heater is accidentally unplugged. Operates for hours from a standard 20 lb. propane tank. Powder coated finish. Patent No. 4,848,313. AGA & CGA Certified.



Model 35-FAC

(35,000 BTU/HR) Forced Air Heater

Economy model - low cost - high heat output. Keeps shops and work areas of up to 6,000 cu. ft. comfortable in the coldest weather. Push button piezoelectric ignition standard. Light weight, compact and operates for hours from a standard 20 lb propane tank. Aluminized steel finish. Certification Pending.



Model 45-FAC

(adjustable 25,000 to 45,000 BTU/HR) Forced Air Heater

This adjustable heater is designed for heat output from 25,000 to 45,000 BTU/HR and a range of heating space from 4,000 to 8,000 cu. ft. Automatic electronic ignition. Propane flow stops if heater is accidentally unplugged. Can operate for hours from a standard 20 lb. propane tank. Powder coated finish. Patent # 5,553,220/AGA & CGA Certified.



Model 80-FAC

(80,000 BTU/HR) Forced Air Heater

Automatic solid state ignition, over temperature limiting switch, high velocity fan and many more safety and performance features. Can be operated with accessory thermostat (#6184) for maximum fuel savings and uniform temperature control. Ideal for medium size jobs up to 15,000 cu. ft. Recommended for use with 40 lb. or larger propane tank. AGA & CGA Certified.



Model 85-FAC

(adjustable 50,000 to 85,000 BTU/HR) Forced Air Heater

Features continuous electronic ignition and adjustable heat output from 50,000 to 85,000 BTU/HR for buildings from 9,000 to 16,000 cu. ft. High output fan for better distribution of heated air. Ignition will not take place unless heater is plugged in. Propane flow stops if heater is accidentally unplugged. Can be operated for hours (at low setting) from a standard 20 lb. tank. Powder coated finish. Patent #5,553,220/AGA & CGA Certified.



Model 125-FAC

(adjustable 75,000 to 125,000 BTU/HR) Forced Air Heater

Similar to the 85-FAC, but with higher heating output. Adjustable from 75,000 to 125,000 BTU/HR and heats from 14,000 to 24,000 cu. ft. Ignition will not take place unless heater is plugged in. Can be operated for hours (at low setting) from a 40 lb. or larger propane tank. Powder coated finish. Patent # 5,553,220 AGA & CGA Certified.



Model 150-FAST

(150,000 BTU/HR) Forced Air Heater with Thermostat

This high output heater is designed for big jobs. Lightweight and features automatic ignition. This unit has a built in thermostat for most economical operation. Heats up to 29,000 cu. ft. Operates from one or more 100 lb. propane tanks. Powder coated finish. AGA & CGA Certified.



Model 150-FANG

(150,000 BTU/HR) Natural Gas Fueled Forced Air Heater

Similar to 150-FAST, but designed to operate on natural gas. Does not include built-in thermostat. Includes 4" WC regulator. Does not include hose. AGA & CGA Certified.

Model 3500-FACV

(adjustable 175,000 to 350,000 BTU/HR) Forced Air Heater with Thermostat

For the big heating jobs. Commercial, industrial, warehouse, construction and agriculture. Heating output can be adjusted from 175,000 to 350,000 BTU/HR to meet the job requirement and a built-in thermostat offers most economical operation. Heats in a range of 34,000 up to 69,000 cu. ft. The long life "Starfire"™ ceramic burner offers quiet operation and better mixing and distribution of heated air. Recommended for use with two or more 100 lb. propane cylinders. Powder coated finish. Patents #5,017,129 and #5,553,220. AGA & CGA Certified.



Model 3500-FACNG

(adjustable to 175,000 to 350,000 BTU/HR) Natural Gas Fueled Forced Air Heater with Thermostat

Similar to 3500-FACV, but designed to operate from a minimum of 15 PSIG high pressure natural gas. Includes 5 - 20 PSIG regulator. Does not include hose. Patent #5,017,129.

Universal

Model 7000-FACV

(adjustable 400,000 to 700,000 BTU/HR) Forced Air Heater with Thermostat

Big heat for big jobs. This highly portable heater features the "Starfire" burner for quieter operation. Compact, quiet and lightweight for its adjustable output of 400,000 to 700,000 BTU/HR. Built-in thermostat. Operates from a 500 gallon or larger tank. Patent #5,017,129/Patent #5,553,220.



Model	30-FAC	35-FAC	45-FAC	80-FAC	85-FAC	125-FAC
Output - BTU/HR	30,000	35,000	25,000-45,000	80,000	50,000-85,000	75,000-125,000
Fuel	Propane Gas	Propane Gas	Propane Gas	Propane Gas	Propane Gas	Propane Gas
Heating Area (sq. ft.)***	700	800	600-1,000	1900	1,200-2,000	1,800-3,000
Fuel Consum. (lbs/hr)	1.4	1.6	1.2 to 2.1	3.7	2.3 to 3.9	3.5 to 5.8
Heated Air Output (cu. ft./min.)	140	100	300	350	350	350
Ignition	Direct Spark Manual	Manual	Continuous	Automatic	Continuous	Continuous
Power Required	115v/60Hz	115v/60Hz	115v/60Hz	115v/60Hz	115v/60Hz	115v/60Hz
Pressure Regulator Setting	11" WC	10 PSIG	28" WC	11" WC	28" WC	28" WC
Flame Safety**	Yes	Yes	Yes	Yes	Yes	Yes
Hose	10' LP	10' LP	10' LP	10' LP	10' LP	10' LP
Size (L x W x H)	16 x 9 x 15	19 x 12 x 14	19 x 12 x 14	23 x 13 x 16	23 x 13 x 16	23 x 13 x 16
Shipping Cube (cu. ft.)	1.11	1.85	1.85	2.77	2.77	2.77
Ship. Wt (lbs)	18	17	20	26	25	25

** In the event of a Flame-Out the safety control valve automatically shuts off the fuel to the pilot & burners.

*** Estimated on room size with 8 ft. ceiling.

Model	150-FAST	150-FANG	3500-FACV	3500-FACNG	7000-FACV
Output - BTU/HR	150,000	150,000	175,000 - 350,000	175,000 - 350,000	400,000 - 700,000
Fuel	Propane Gas	Natural Gas	Propane Gas	Natural Gas	Propane Gas
Heating Area (Sq. Ft.)***	3,600	3,600	4,300 - 8,600	4,300 - 8,600	9,800 - 17,000
Fuel Consum. (lbs/hr)	7 lbs.	150 cu. ft.	8.0 to 16 lbs.	172 to 374 cu. ft.	18.5 to 32.4 lbs.
Heated Air Output (cu. ft./min.)	450	450	1400	1400	2800
Ignition	Automatic	Automatic	Automatic	Automatic	Automatic
Power Required	115v/60Hz	115v/60Hz	115v/60Hz	115v/60Hz	115v/60Hz
Pressure Regulator Setting	11" WC	4" WC	20 PSIG	20 PSIG	20 PSIG
Flame Safety**	Yes	Yes	Yes	Yes	Yes
Hose	10' LP	none	10' LP	none	10' LP
Size (L x W x H)	28 x 11 x 17	28 x 11 x 17	32 x 15 x 21	32 x 15 x 21	29 x 54 x 34
Shipping Cube (cu. ft.)	3.03	3.03	5.83	5.83	30.81
Ship. Wt (lbs)	30	29	50	49	143

** In the event of a Flame-Out the safety control valve automatically shuts off the fuel to the pilot & burners.

*** Estimated on room size with 8 ft. ceiling.

PROPANE & NATURAL GAS CONVECTION

Model 25-VC

(3 settings 15,000 - 20,000 - 25,000 BTU/HR) Convection Heater

Available for smaller job sites, such as workshops and emergencies. No electrical connection required. Heats from 2,000 to 4,000 cu. ft. with low fuel consumption. Piezoelectric pilot ignitor is standard. Will operate for hours from a standard 20 lb. propane tank.



Model 80-VC

(adjustable 30,000 to 80,000 BTU/HR) Convection Heater

Offers adjustable heating from 30,000 to 80,000 BTU/HR to handle small to medium size jobs, such as workshops and outbuildings. Heats from 5,000 to 15,000 cu. ft. Piezoelectric pilot light ignitor is standard on this compact-light-weight heater. No electrical connection required. Ideal for remote buildings or where electrical service is not available. Low pressure design makes for quiet operation. Can be operated for hours (at low setting) from a standard 20 lb. propane tank. AGA & CGA Certified.



Model 80-VCNG

(adjustable 30,000 to 60,000 BTU/HR) Natural Gas Fueled Convection Heater

Similar to the 80-VC, but designed to operate from natural gas. 4" WC regulator included. Does not include hose.

Model 225-VC

(adjustable 75,000 to 200,000 BTU/HR) Convection Heater

Handles big heating job requirements for drywalling, concrete curing, warehouses, industry and agriculture without requiring any electrical connections. Adjustable heating output from 75,000 to 200,000 BTU/HR allows for use in medium to large buildings. Features a piezoelectric pilot light ignitor and heats from 14,000 to 39,000 cu. ft. Recommended for use with one or more 100 lb propane cylinders. Certification pending.



Model 225-S

(adjustable 75,000 to 200,000 BTU/HR) Convection Heater

Same as the 225-VC, but has no piezoelectric ignitor.

Model	25-VC	80-VC	80-VCNG	225-VC	225-S
Output - BTU/HR	15,000 - 20,000 - 25,000	30,000 - 80,000	30,000 - 60,000	75,000 - 200,000	75,000 - 200,000
Fuel	Propane Gas	Propane Gas	Natural Gas	Propane Gas	Propane Gas
Heating Area (sq. ft.)***	300 - 600	700 - 1,900	700 - 1,900	1,800 - 4,900	1,800 - 4,900
Fuel Consum. (lbs/hr)	0.7 to 1.16 lbs.	1.4 to 3.7 lbs.	27 to 55 cu. ft.	3.5 to 9.3 lbs.	3.5 to 9.3 lbs.
Ignition	Piezoelectric Pilot Ignitor	Piezoelectric Pilot Ignitor*	Piezoelectric Pilot Ignitor*	Piezoelectric Pilot Ignitor*	Manual
Power Required	none	none	none	none	none
Pressure Regulator Setting	10 - 15 PSIG	11" WC	4" WC	10 PSIG	10 PSIG
Flame Safety**	Yes	Yes	Yes	Yes	Yes
Hose	10' LP	10' LP	none	10' LP	10' LP
Size (L x W x H)	12 x 12 x 13	16 x 12 x 22	16 x 12 x 22	18 x 13 x 27	18 x 13 x 27
Shipping Cube (cu. ft.)	1.08	2.44	2.44	3.66	3.66
Ship. Wt (lbs)	12	20	20	24	24

* Pilot will allow main burner to be turned on & off without relighting once the pilot has been ignited.

** In the event of a Flame-Out the safety control valve automatically shuts off the fuel to the pilot & burners.

*** Estimated on room size with 8 ft. ceiling.

Equipment

Universal

PROPANE & NATURAL GAS RADIANT

Model 100-RA

(100,000 BTU/HR) 360° Radiant Heater

Ideal space heater for drafty or large areas. Infrared rays produced from the emitter surface, radiates heat in a full circle to warm surrounding people and objects. Piezoelectric pilot light ignitor is standard. No electrical connection required. Recommended for use with 100 lb. propane cylinder. AGA & CGA Certified.

Model 100-RANG

(100,000 BTU/HR) Natural Gas Fueled 360° Radiant Heater

Produces 100,000 BTU/HR and operates from natural gas. Includes 4" WC regulator. Does not include hose. AGA & CGA Certified

Model 250-RA

(250,000 BTU/HR) 360° Radiant Heater

Ideal space heater for drafty or large areas. Infrared rays produced from the emitter surface, radiates heat in a full circle to warm surrounding people and objects. Piezoelectric pilot light ignitor is standard. No electrical connection required. Recommended for use with 100 lb. propane cylinder.

Model 250-RANG

(250,000 BTU/HR) Natural Gas Fueled 360° Radiant Heater

Produces 250,000 BTU/HR and operates from high pressure natural gas. Includes 5 PSI regulator. Does not include hose.

Model 42-PH

(40,000 BTU/HR) Radiant Patio Heater

Ideal for patios, restaurants and any open air service areas. Operates for hours from a standard 20 lb. propane tank, which can be concealed in the base of the unit. Sun-like radiant heat covers a 12' to 15' circle. Piezoelectric pilot light ignitor is standard, with no electrical connections required. Weather resistant powder coated finish. Certification pending.



PROPANE INFRARED

12-IR (11,000 BTU/HR) Infrared Heaters

24-IR (22,000 BTU/HR) Infrared Heaters

36-IR (33,000 BTU/HR) Infrared Heaters

48-IR (44,000 BTU/HR) Infrared Heaters

Ideal for heating people or objects economically in large open spaces. Space age ceramic emitters and stainless steel reflectors deliver infrared rays for maximum radiant heat range. Heavy duty brazed steel manifold connects individual radiant generators for maximum structural integrity. All models include mounting bracket for mounting to propane tank rim, hose and 28" WC regulator. No electricity required. Models 12-IR, 24-IR and 36-IR can be mounted directly to the rim of a standard 20 lb. propane tank for hours of operation. The 48-IR will operate for hours on a 40 lb. or larger propane tank.



Model 36-AP

(33,000 BTU/HR) Infrared "All Purpose" Patio/Deck Heater

This model offers additional benefits and features of adjustable height stand with base, tank mount and piezoelectric push button ignitor. The 36-AP is designed to deliver radiant heat more effectively through height and directional control. Ideal for patios, decks, pool sides, work areas and open air service areas. No electricity required. Can be operated for hours from a 20 lb. propane tank.

Propane Infrared Chart:					
Model	12-IR	24-IR	36-IR	48-IR	36-AP
Output - BTU/HR	11,000	22,000	33,000	44,000	33,000
Fuel	Propane Gas	Propane Gas	Propane Gas	Propane Gas	Propane Gas
Fuel Consum. (lbs./hr.)	0.50 lbs.	1.0 lbs.	1.5 lbs.	2.2 lbs.	1.5 lbs.
Ignition	Manual	Manual	Manual	Manual	Piezo
Power Required	none	none	none	none	none
Pressure Regulator Setting	28" WC	28" WC	28" WC	28" WC	28" WC
Flame Safety**	Yes	Yes	Yes	Yes	Yes
Hose	30" LP	30" LP	30" LP	30" LP	6' LP
Size (L x W x H)	11 x 9 x 8	14 x 11 x 8	27 x 11 x 6	23 x 19 x 6	46 x 19 x 7
Shipping Cube (cu. ft.)	0.46	0.68	0.99	1.49	3.35
Ship. Wt (lbs)	6	8	11	14	44

** In the event of a Flame-Out the safety control valve automatically shuts off the fuel to the pilot & burners.

Propane and Natural Gas Radiant Chart:					
Model	42-PH	100-RA	100-RANG	250-RA	250-RANG
Output - BTU/HR	40,000	100,000	100,000	250,000	250,000
Fuel	Propane Gas	Propane Gas	Natural Gas	Propane Gas	Natural Gas
Heating Area (sq. ft.)***	-	2,400	2,400	6,100	6,100
Fuel Consum. (lbs/hr)	1.86 lbs.	4.6 lbs.	100 cu. ft.	11.6 lbs.	250 cu. ft.
Ignition	Piezoelectric Pilot Ignitor*	Piezoelectric Pilot Ignitor*	Piezoelectric Pilot Ignitor*	Piezoelectric Pilot Ignitor*	Piezoelectric Pilot Ignitor*
Power Required	none	none	none	none	none
Pressure Regulator Setting	11" WC	11" WC	4" WC	10 PSIG	5 PSIG
Flame Safety**	Yes	Yes	Yes	Yes	Yes
Hose	10' LP	10' LP	none	10' LP	none
Size (L x W x H)	24 x 35 x 36	16 x 16 x 31	16 x 16 x 31	47 x 16 x 16	47 x 16 x 16
Shipping Cube (cu. ft.)	18.00	4.59	4.59	6.96	6.96
Ship. Wt (lbs)	107	30	28	37	36

* Pilot will allow main burner to be turned on & off without relighting once the pilot has been ignited.

** In the event of a Flame-Out the safety control valve automatically shuts off the fuel to the pilot & burners.

*** Estimated on room size with 8 ft. ceiling.

Enerco/Heatstar

Enerco/ Heatstar

Portable Tank Top Heater

- Tip-over safety shut-offs • Soft nose P.O.L.
- Premium grade stainless steel burning surface
- Direct connection to 20lb. bulk propane tank
- Operate one or two or three burners at a time
- Directional, adjustable heads
- Polished chrome reflector
- Outdoor use only
- CSA certified



Model #	Description
F242100	MH15T Heater - 10,000-15,000 BTU/Hr.
F242650	MH30T Heater - 10,000-30,000 BTU/Hr.
F242915	MH45T Heater - 10,000-45,000 BTU/Hr.

Convection Heaters

- HS80CVX heats approx. 2,000 sq. ft. and runs up to 14 hrs. on 20lb. tank (low)
- HS100CVNG heats approx. 2,500 sq. ft.
- HS200CVX heats approx. 5,000 sq. ft. and runs up to 29 hrs. on 100lb. tank (low)
- Piezo push button igniter
- Telescoping chamber for reduced ship space
- Instant locking chamber for easy assembly
- 20' hose and regulator included on HS80CVX & HS200CVX
- CSA certified



Specifications:	HS80CVX	HS100VNG	HS200CVX
Stock #	F170470	F170473	F170475
Output (BTU/HR)	30,000-80,000	50,000 - 100,000	75,000-200,000
Heating Area (SQ. FT.)	2,000	2,500	5,000
Fuel	Propane Gas	Natural Gas	Propane Gas
Propane Consumption (lbs/hr)	1.4 to 3.7	-	3.5 to 9.3
Pressure Regulator Settings	10 PSI	5" W.C.	10 PSI
Flame Safety*	Thermocouple Operated Gas Valve	Thermocouple Operated Gas Valve	Thermocouple Operated Gas Valve
Standing Pilot	Yes	Yes	Yes
Ignition	Piezo	Piezo	Piezo
Hose 20ft.	3/8" I.D. w/Regulator and POL	NA w/Natural Gas	1/4" I.D. w/Regulator and POL
POL/Excess Flow Check Valve	Yes	NA w/Natural Gas	Yes
Shipping size (L x W x H)	15.25" x 18.25" x 21.75"	15.25" x 18.25" x 21.75"	18.25" x 15" x 27.5"
Shipping Weight	21 lbs.	21 lbs.	27 lbs.

Forced Air Propane

- For use with propane gas
- Rugged and durable steel construction
- Economical, efficient and clean burning
- Heavy duty high output fan
- Hose and regulator included



Model #	Description	Heats up to	Operates up to
F170035	HS35FA 35,000 BTU/HR	800 Sq. Ft.	12 hrs. on a 20 lb. tank
F170085	HS85FAV 50,000-85,000 BTU/HR	2,000 Sq. Ft.	8 hrs. on a 20 lb. tank
F170125	HS125FAV 75,000-125,000 BTU/HR	3,000 Sq. Ft.	11 hrs. on a 40 lb. tank
For Large Jobsites			
F170170	HS170FAVT 125,000-170,000 BTU/HR	4,000 Sq. Ft.	17 hrs. on a 100 lb. tank
F172425	HS400FAVT 250,000-400,000 BTU/HR	10,000 Sq. Ft.	17 hrs. on (2) 100 lb. tanks

Forced Air Kerosene

- Heavy construction - illuminated on-off switch - 115 V 60Hz
- Flame safety/overheat safety shutoff
- Enclosed motor - fuel gauge
- Continuous ignition
- Cord wrap (HS75KT only) - high output fan
- Large "glove-friendly" controls
- Operates using kerosene, JP8 (Jet A Fuel), filtered #1 and #2 diesel, and #1 and #2 fuel oil
- CSA certified



Part #	HS50K	HS75KT	HS125KT	HS175KT	HS210KT
Model #	F170250	F170275	F170325	F170375	F170380
Output (BTU/HR)	50,000	75,000	125,000	175,000	210,000
Heating Area (SQ. FT.)	1,200	1,750	3,000	4,250	6,000
CFM Output	165	240	275	400	400
Fuel Consumption (GAL/HR-L/HR)	.38/1.43	.56/2.11	.77/2.91	1.15/4.35	1.60/6.05
Tank Capacity (GAL-L)	4/15	6/22	14/52	14/52	14/52
Tires/Wheels	NA	NA	Solid Foam Filled	Solid Foam Filled	Solid Foam Filled
Operating Hours On Full Tank	11	11	15	10	8
Shipping Size	32" x 14" x 14.5"	32" x 14.25" x 17"	42" x 18" x 22"	42" x 18" x 22"	42" x 18" x 22"
Weight	43 lbs	43 lbs	74 lbs	81 lbs	87 lbs

Equipment

Pinnacle/Master

Kerosene Forced Air Torpedo Heaters



Model #	MH-45-KFA	MH-75T-KFA	MH-135T-KFA	MH-190T-KFA
Heat Output	45,000 BTU	75,000 BTU	135,000 BTU	190,000 BTU
Heating Area	1,100 sq. ft.	1,875 sq. ft.	3,375 sq. ft.	4,750 sq. ft.
Fuel Tank Capacity	5 gal	5 gal	10 gal	13 gal
Fuel Consumption	5 gal/hr	0.56 gal/hr	1.00 gal/hr	1.42 gal/hr
Max Operating Hrs.	14	9	10	9
Air Flow	170 CFM	240 CFM	540 CFM	630 CFM

Propane Forced Air Torpedo Heaters



Model #	MH-45-KFA	MH-75T-KFA	MH-135T-KFA	MH-190T-KFA
Heat Output	45,000 BTU	75,000 BTU	135,000 BTU	190,000 BTU
Heating Area	1,100 sq. ft.	1,875 sq. ft.	3,375 sq. ft.	4,750 sq. ft.
Fuel Tank Capacity	5 gal	5 gal	10 gal	13 gal
Fuel Consumption	5 gal/hr	0.56 gal/hr	1.00 gal/hr	1.42 gal/hr
Max Operating Hrs.	14	9	10	9
Air Flow	170 CFM	240 CFM	540 CFM	630 CFM

**If your tools aren't working...
neither are YOU!**

Prevent unnecessary downtime and cost by using HSI's repair department!



- HSI is an authorized warranty center with factory authorized/certified technicians to get you and your tools back to work quickly!
- With 50 years combined experience, HSI technicians can quickly diagnose and repair your problems.
- Preventative maintenance program - general maintenance, minor adjustments, greased when needed and other minor repairs at a reduced rate - talk to sales today for more information!

Quality workmanship, quick turnaround and great customer service are our priorities.



Call our repair division for more information **716.826.2636**

Honda Generators/ Pumps



Generators

	Vendor #	Engine	AC Output	Receptacles	Runtime per tankful	Noise Level
Industrial Series						
A	EB2000i	Honda GX100	120V 2000W max. 1600W rated	20A 125V GFCI Duplex	3.4hr @ rated load, 8.1 hrs @ 1/4 load	59 dB(A) @ rated load, 53 dB(A) @ 1/4 load
B	EB2800i	Honda GC190LA	120V 2800W max. 2500W rated	20A 125V GFCI Duplex 30A 125V Locking Plug	5.1 hrs @ rated load, 2.1 hrs @ 1/4 load	69 dB(A) @ rated load, 61 dB(A) @ 1/4 load
C	EB5000X	Honda iGX390	120/240V 5000W max. 4500W rated	20A 125V GFCI Duplex (2), 30A 125V Locking Plug, 30A 125/250V Locking Plug	8.1 hrs @ rated load, 11.2 hrs @ 1/2 load	72 dB(A) @ rated load
	EB6500X	Honda iGX390	120/240V 6500W max. 5500W rated	20A 125V GFCI Duplex (2), 30A 125V Locking Plug, 30A 125/250V Locking Plug	6.9 hrs @ rated load, 10.4 hrs @ 1/2 load	73 dB(A) @ rated load
Inverter Generators - Super Quiet Series						
D	EU2000i	Honda GX100	120V 2000W max. 1600W rated	20A 125V Duplex	3.4hr @ rated load, 8.1 hrs @ 1/4 load	59 dB(A) @ rated load, 53dB(A) @ 1/4 load
	EU2000i companion	Honda GX100	120V 2000W max. 1600W rated	30A 125V Locking Plug, 20A 125 V receptacle	3.4hr @ rated load, 8.1 hrs @ 1/4 load	59 dB(A) @ rated load, 53dB(A) @ 1/4 load
E	EU7000is	Honda GX390 EFI	120/240V 7000W max. 5500W rated	20A 125V GFCI Duplex (2), 30A 125V Locking Plug, 30A 125/250V Locking Plug	6.5 hrs. @ rated load, 18.0 hrs. @ 1/4 load	60 dB(A) @ rated load, 52 dB(A) @ 1/4 load



Pumps

	Vendor #	Description	Discharge Capacity	Total Headlift	Dry Weight	Run Time
A	WX10	1" De-Watering Pump	32 gal./min.	121 ft	13 lbs	.9 hr
B	WX20	2" Trash Pump	185 gal./min.	95 ft	104 lbs	1.5 hr
C	WB20	2" General Purpose Pump	184 gal./min.	105 ft	44 lbs	1.7 hr
D	WB30	3" General Purpose Pump	290 gal./min.	95 ft	57 lbs	1.9 hr

